

## Footprints en technische gegevens T 110 I

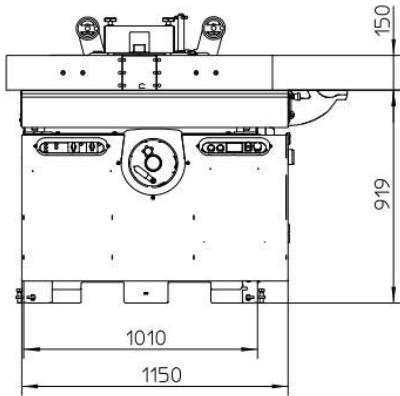

Spanning	Tension	Spannung	Tension	3 x 230V / 3 x 400V / 3 x 600V
Gewicht	Weight	Gewicht	Poids	530kg
Afmeting tafel	Dimensions table	Abmessing Tisch	Dimensions table	1000 x 520
Tafelhoogte	Table Height	Tischhöhe	Hauteur de la table	920mm
Topas lengte	Spindle length	Spindellänge	Longeur d'arbre	150 mm
Hoogteverplaatsing	Spindle stroke	Höheverstellung	Course d'arbre	150mm
Topas dia	Shaft diameter	Spindeldurchmesser	Diamètre arbre	30/40/50
Onderhoek	Angle spindle	Schrägverstellung	Inclinaison	-5° / +45°
Loopwagen	Slidingtable	Schiebetisch	Chariot	1400
Opening tafel	Table opening	Tischöffnung	Ouverture de table	260 x 60 mm
Toerental	RPM	U/MIN	Vitesse	3000/4500/6000/7000/10000
vermogen	Motor power	Leistung Hobelmotor	Puissance du moteur	7.35 kW / 9.2 kW
Stofafzuiging	Dustcollecting	Absaugung	Aspirateur	120mm

