



Inhoudsopgave freescatalogus:

Pagina 1	: Universele profielmessenkop 40 mm.
Pagina 2	: Universele profielfreeset 40 mm.
Pagina 3 – 21	: Universele profielmessen 40 mm.
Pagina 22	: Universele profielmessenkop 50 mm.
Pagina 23	: Universele profielfreeset 50 mm.
Pagina 24 – 30	: Universele profielmessen 50 mm.
Pagina 31	: HM groeffrees
Pagina 32	: HM keermes groeffrees
Pagina 33 + 34	: Verstelbare groeffrees
Pagina 35	: Kopieerset
Pagina 36 + 37	: Schuinstelbare hoekfrees
Pagina 38	: Verlijmfrees
Pagina 39	: Hoekverlijmfrees
Pagina 40	: Profiel / contra profielfrees
Pagina 41 + 42	: Panelen / bossingfrees
Pagina 43	: HM keermes afrondfrees
Pagina 44 + 45	: Multiprofielfrees
Pagina 46	: Trapleuningfrees
Pagina 47	: Schaafmessen
Pagina 48 + 49	: HSS langgatboren
Pagina 50	: Tussenringen
Pagina 51	: Kopieerringen / lagers
Pagina 52 + 53	: HM cirkelzaagbladen
Pagina 54 + 55	: Nederlandse standaard profielen
Pagina 56	: HM keermessen
Pagina 57	: Stelklokken

Universeel profielmessenkop

Aluminium freesbody

Artikel-Nummer item no./num. art.	∅ TD (mm)	B (mm)	d (mm)		z		n min. - max.	
03.100.040.030.A	100	40	30		2		5500 - 8400	
03.120.040.030.A	120	40	30 - 50		2		4800 - 7400	

MAN 

Aluminium freesbody

Artikel-Nummer item no./num. art.	∅ TD (mm)	B (mm)	d (mm)		z		n min. - max.	
04.100.040.030.A	100	40	30		2		5500 - 8400	
04.120.040.030.A	120	40	30 - 50		2		4800 - 7400	

MEC 

Aluminium freesbody

Artikel-Nummer item no./num. art.	∅ TD (mm)	B (mm)	d (mm)		z	V	n min. - max.	
03.098.040.030A1	96	40	30		2	1 + 1	5800 - 9000	

MAN 

Aluminium freesbody

Artikel-Nummer item no./num. art.	∅ TD (mm)	B (mm)	d (mm)		z	V	n min. - max.	
04.120.040.030A1	118	40	30 - 50		2	1 + 1	5100 - 7900	

MEC 

Universeel profielfreeset

Man uitvoering met 3 set messen

Artikel-Nummer item no./s.nm. art.	Werkzeug tool/outil	Grundkörper tool body corps de base	Anzahl Profile number of profiles quantité de profils	Profil-Nr. profile numbers num. des profils	
20.HK.03.40.03P/Stahl	03.093.040.030.\$	Stahl/steel/acier	3	1 – 3	



Man uitvoering met 6 set messen

Artikel-Nummer item no./s.nm. art.	Werkzeug tool/outil	Grundkörper tool body corps de base	Anzahl Profile number of profiles quantité de profils	Profil-Nr. profile numbers num. des profils	
20.HK.03.40.06P/Stahl	03.093.040.030.\$	Stahl/steel/acier	6	1 – 6	



Man uitvoering met 12 set messen

Artikel-Nummer item no./s.nm. art.	Werkzeug tool/outil	Grundkörper tool body corps de base	Anzahl Profile number of profiles quantité de profils	Profil-Nr. profile numbers num. des profils	
20.HK.03.40.12P/Stahl	03.093.040.030.\$	Stahl/steel/acier	12	1 – 12	



Universeel profielmessen

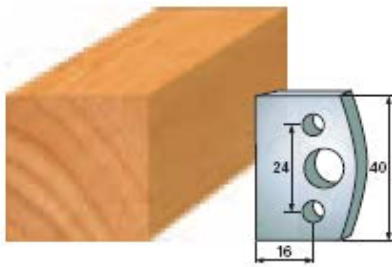

F 190 SP
F 4190 HS
A 190

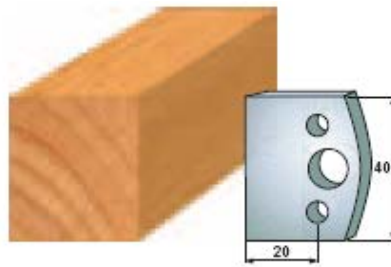

F 191 SP
F 4191 HS
A 191

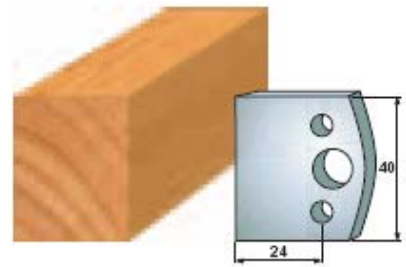

F 192 SP
F 4192 HS
A 192

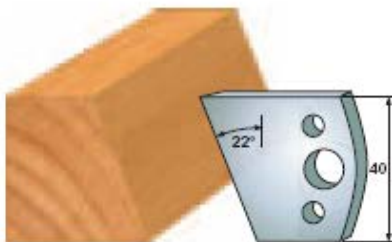

F 01 SP
F 4001 HS
A 01

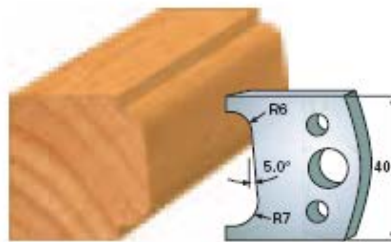

F 02 SP
F 4002 HS
A 02

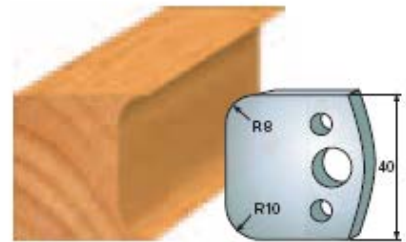

F 03 SP
F 4003 HS
A 03

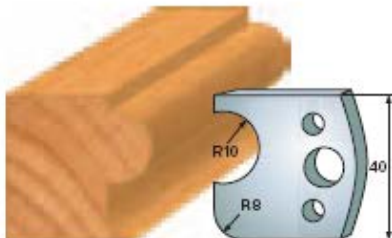

F 04 SP
F 4004 HS
A 04



F 05 SP
F 4005 HS
A 05

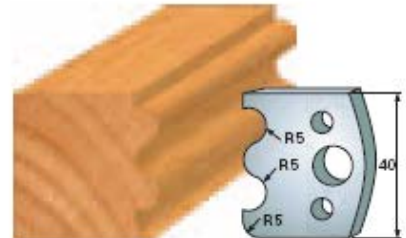

F 06 SP
F 4006 HS
A 06

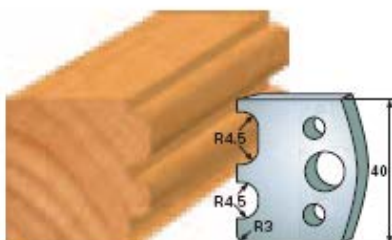

F 07 SP
F 4007 HS
A 07

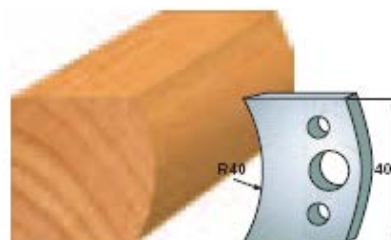

F 08 SP
F 4008 HS
A 08

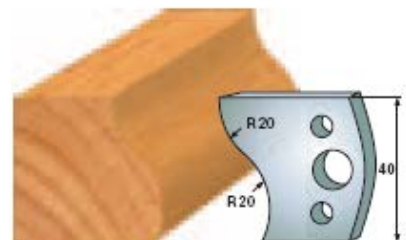

F 09 SP
F 4009 HS
A 09

Universeel profielmessen

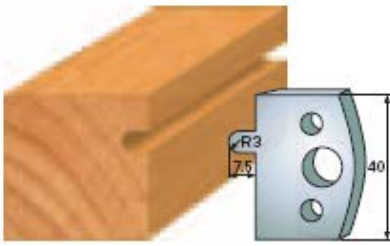

F 10 SP
F 4010 HS
A 10

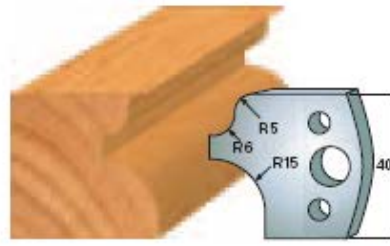

F 11 SP
F 4011 HS
A 11

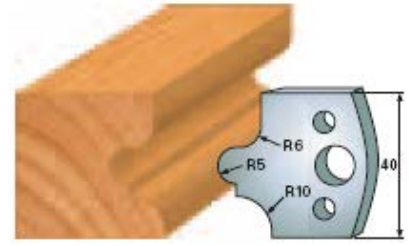

F 12 SP
F 4012 HS
A 12

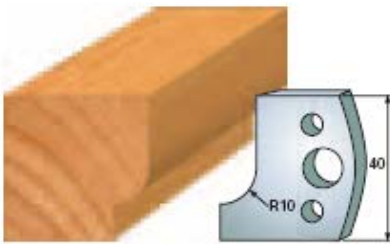

F 13 SP
F 4013 HS
A 13

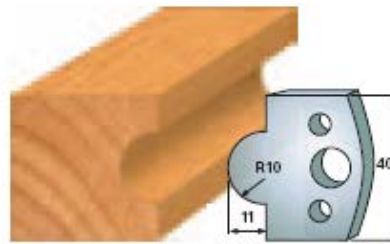

F 14 SP
F 4014 HS
A 14

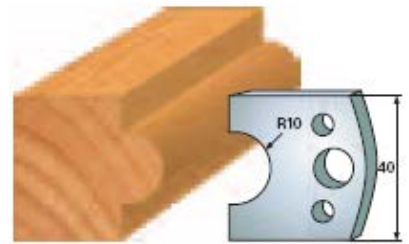

F 15 SP
F 4015 HS
A 15

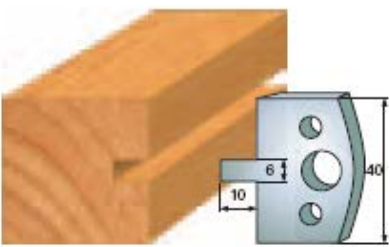

F 16 SP
F 4016 HS
A 16

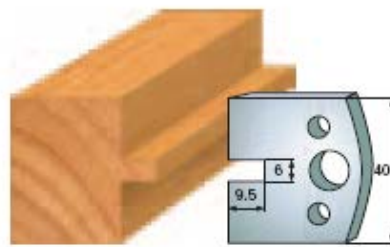

F 17 SP
F 4017 HS
A 17

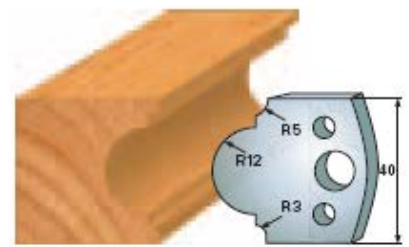

F 18 SP
F 4018 HS
A 18

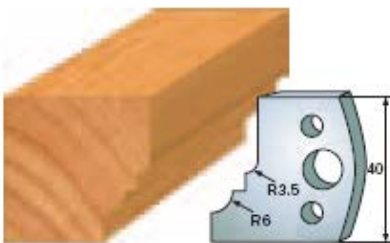

F 19 SP
F 4019 HS
A 19

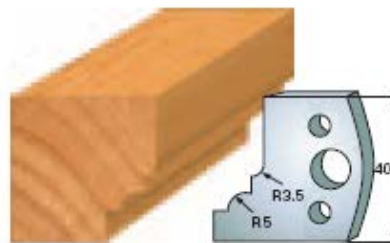

F 20 SP
F 4020 HS
A 20

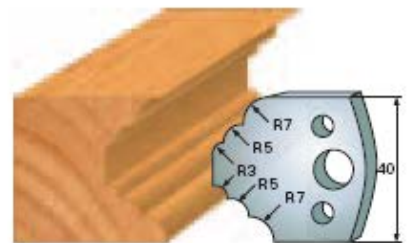

F 21 SP
F 4021 HS
A 21

Universeel profielmessen

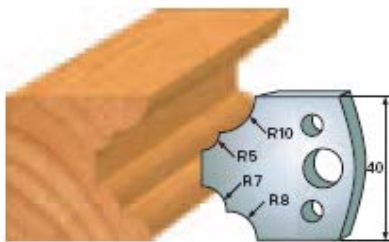

F 22 SP
F 4022 HS
A 22

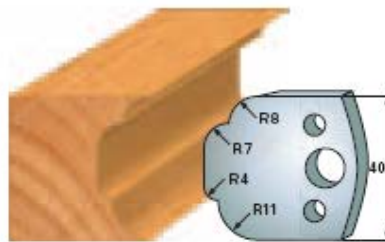

F 23 SP
F 4023 HS
A 23

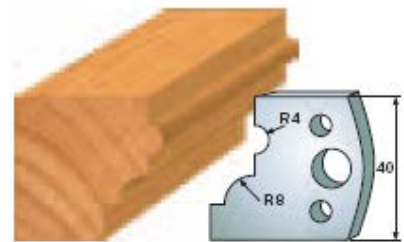

F 24 SP
F 4024 HS
A 24

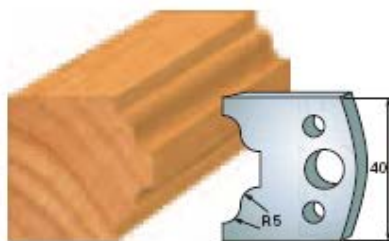

F 25 SP
F 4025 HS
A 25

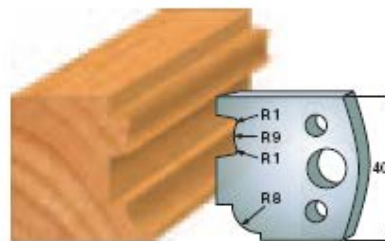

F 26 SP
F 4026 HS
A 26

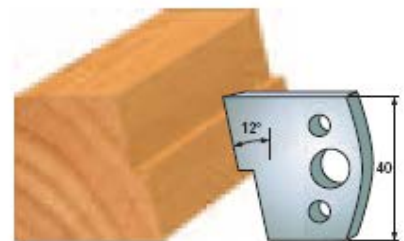

F 27 SP
F 4027 HS
A 27



F 28 SP
F 4028 HS
A 28



F 29 SP
F 4029 HS
A 29

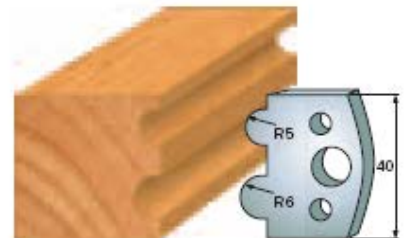

F 30 SP
F 4030 HS
A 30

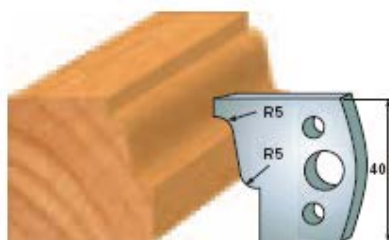

F 31 SP
F 4031 HS
A 31

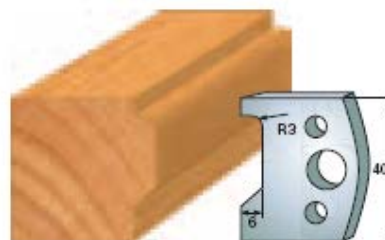

F 32 SP
F 4032 HS
A 32

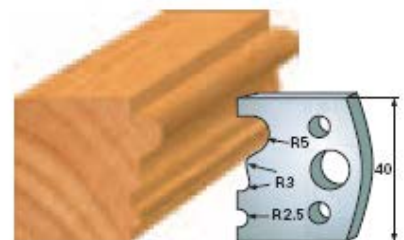

F 33 SP
F 4033 HS
A 33

Universeel profielmessen

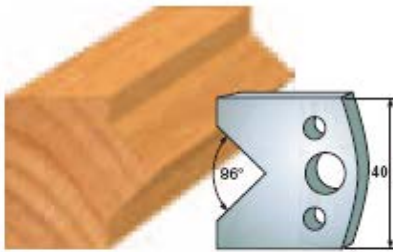

F 34 SP
F 4034 HS
A 34

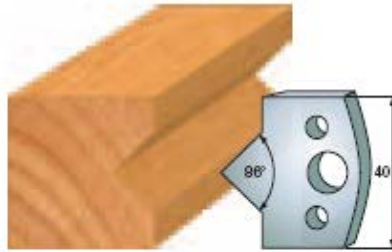

F 35 SP
F 4035 HS
A 35

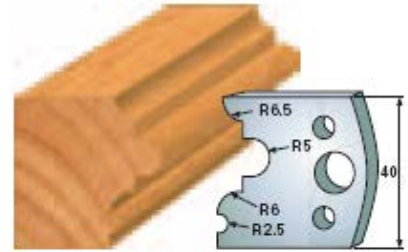

F 36 SP
F 4036 HS
A 36

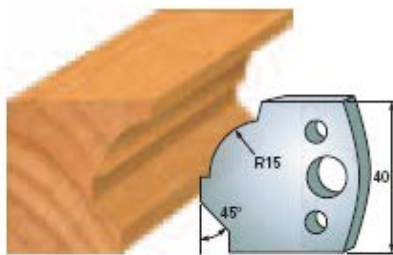

F 37 SP
F 4037 HS
A 37

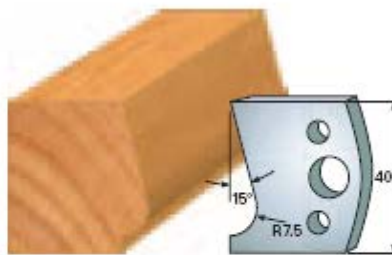

F 38 SP
F 4038 HS
A 38

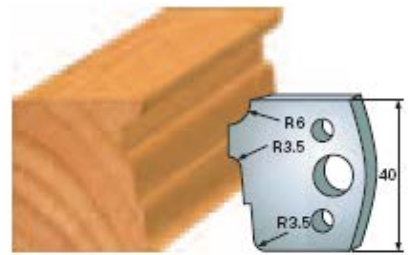

F 39 SP
F 4039 HS
A 39



F 40 SP
F 4040 HS
A 40

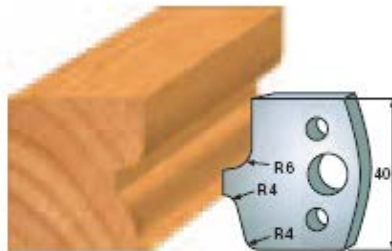

F 41 SP
F 4041 HS
A 41

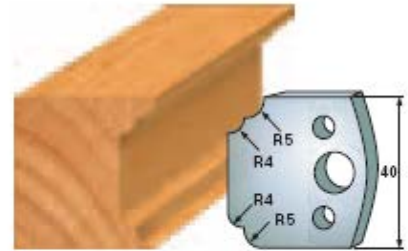

F 42 SP
F 4042 HS
A 42

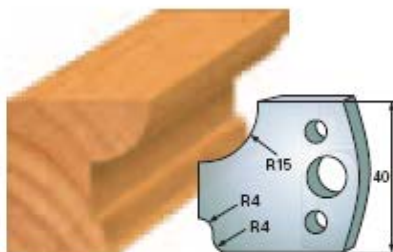

F 43 SP
F 4043 HS
A 43

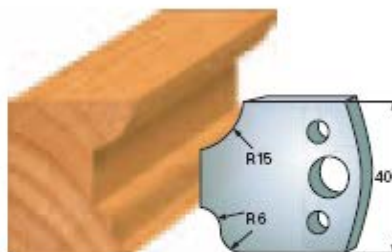

F 44 SP
F 4044 HS
A 44

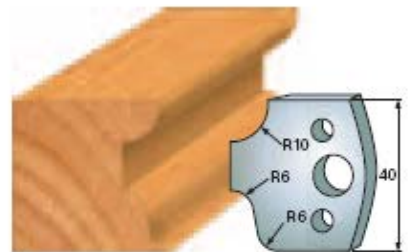

F 45 SP
F 4045 HS
A 45

Universeel profielmessen

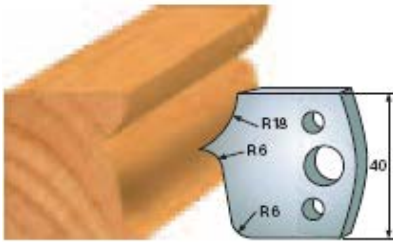

F 46 SP
F 4046 HS
A 46

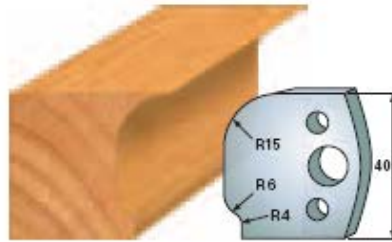

F 47 SP
F 4047 HS
A 47

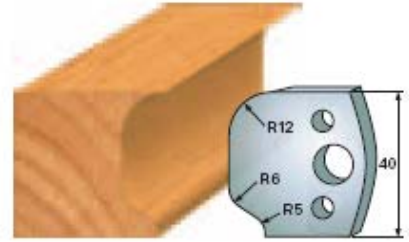

F 48 SP
F 4048 HS
A 48

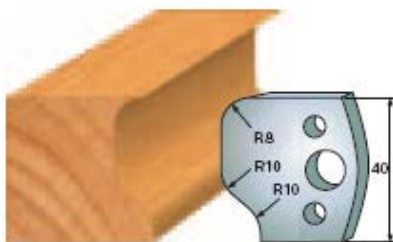

F 49 SP
F 4049 HS
A 49



F 50 SP
F 4050 HS
A 50



F 51 SP
F 4051 HS
A 51

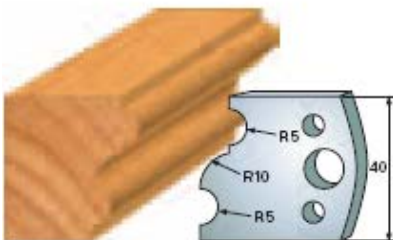

F 52 SP
F 4052 HS
A 52

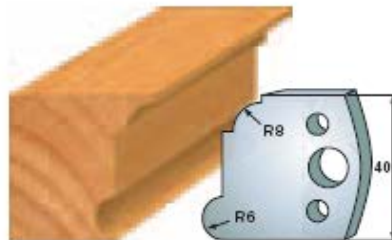

F 53 SP
F 4053 HS
A 53

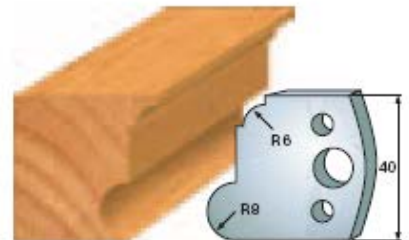

F 54 SP
F 4054 HS
A 54

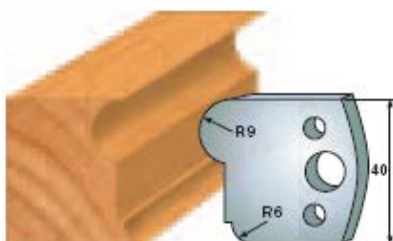

F 55 SP
F 4055 HS
A 55

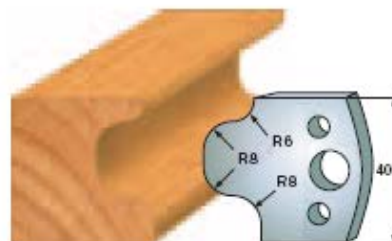

F 56 SP
F 4056 HS
A 56

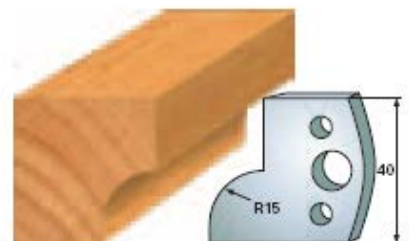

F 57 SP
F 4057 HS
A 57

Universeel profielmessen

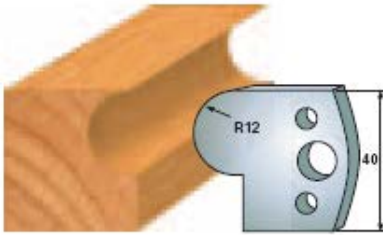

F 58 SP
F 4058 HS
A 58

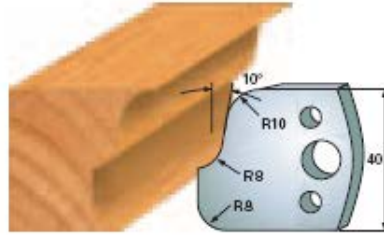

F 59 SP
F 4059 HS
A 59

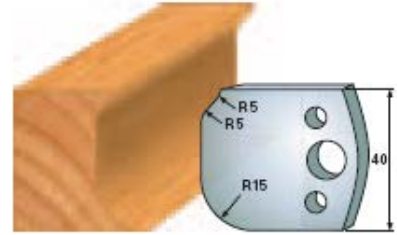

F 60 SP
F 4060 HS
A 60

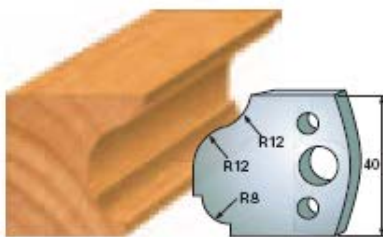

F 61 SP
F 4061 HS
A 61

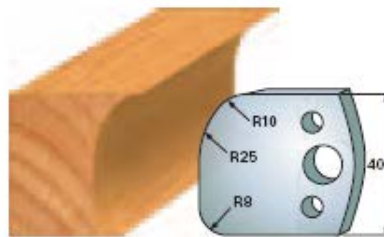

F 62 SP
F 4062 HS
A 62

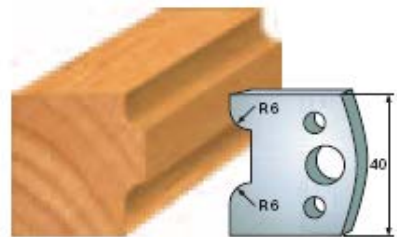

F 63 SP
F 4063 HS
A 63

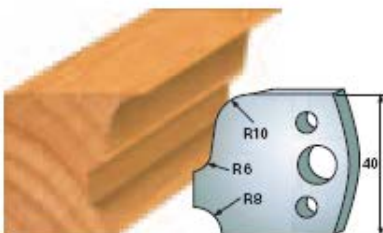

F 64 SP
F 4064 HS
A 64

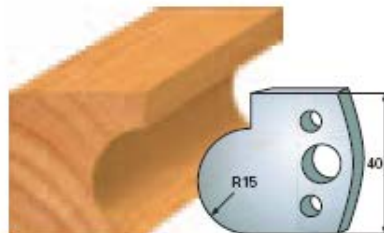

F 65 SP
F 4065 HS
A 65



F 66 SP
F 4066 HS
A 66

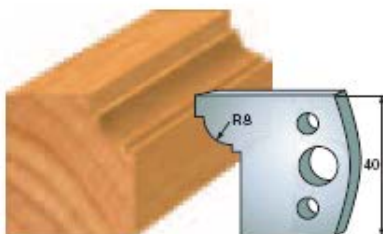

F 67 SP
F 4067 HS
A 67

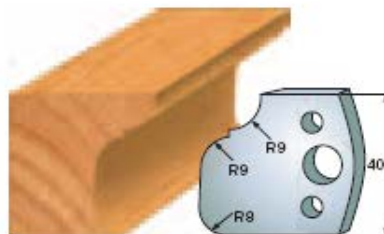

F 68 SP
F 4068 HS
A 68



F 69 SP
F 4069 HS
A 69

Universeel profielmessen

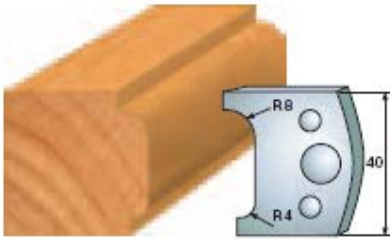

F 70 SP
F 4070 HS
A 70

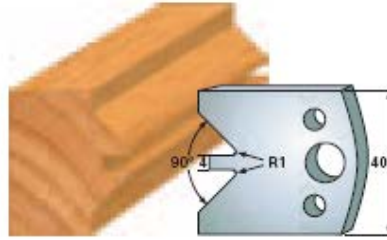

F 71 SP
F 4071 HS
A 71

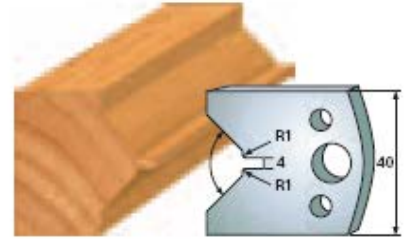

F 72 SP
F 4072 HS
A 72

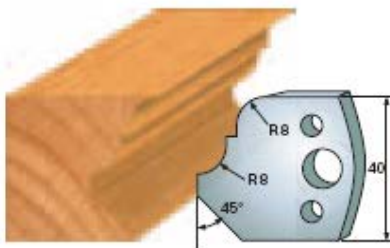

F 73 SP
F 4073 HS
A 73

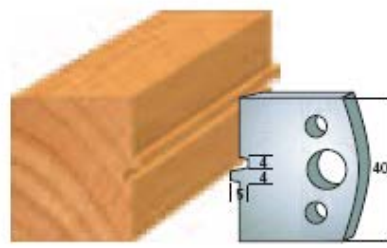

F 74 SP
F 4074 HS
A 74

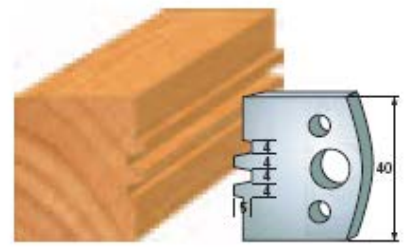

F 75 SP
F 4075 HS
A 75

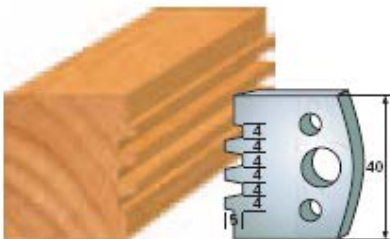

F 76 SP
F 4076 HS
A 76

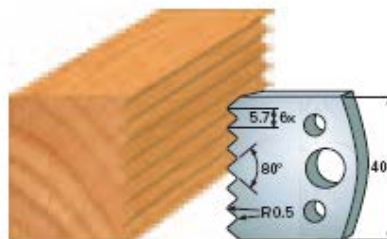

F 77 SP
F 4077 HS
A 77

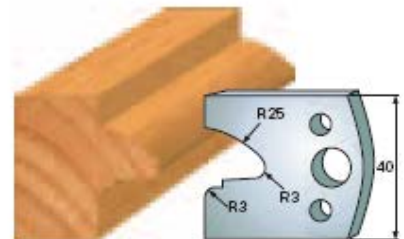

F 78 SP
F 4078 HS
A 78

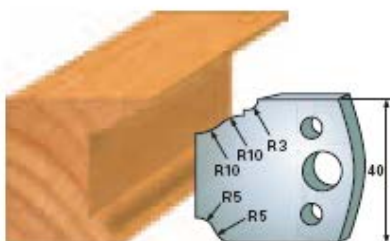

F 79 SP
F 4079 HS
A 79

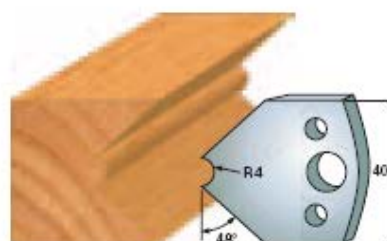

F 80 SP
F 4080 HS
A 80

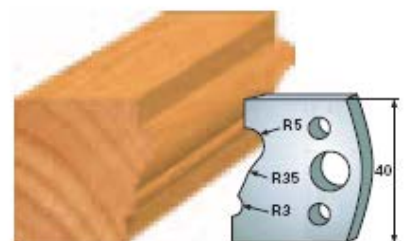

F 81 SP
F 4081 HS
A 81

Universeel profielmessen

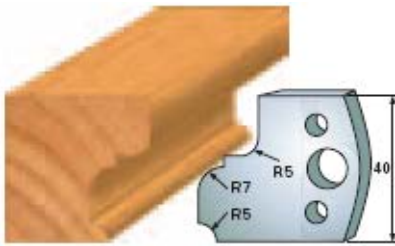

F 82 SP
F 4082 HS
A 82

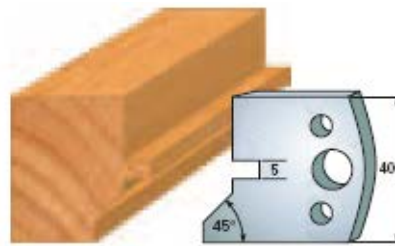

F 83 SP
F 4083 HS
A 83

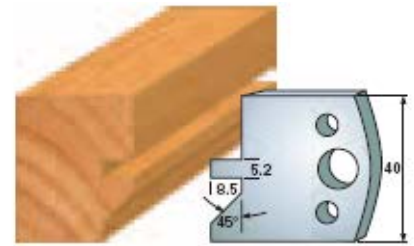

F 84 SP
F 4084 HS
A 84

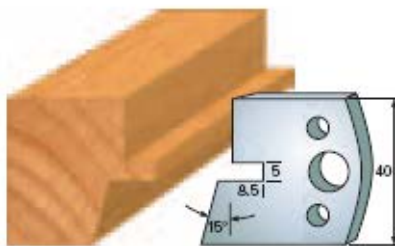

F 85 SP
F 4085 HS
A 85

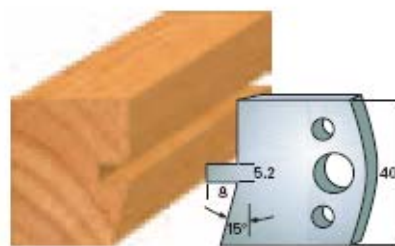

F 86 SP
F 4086 HS
A 86

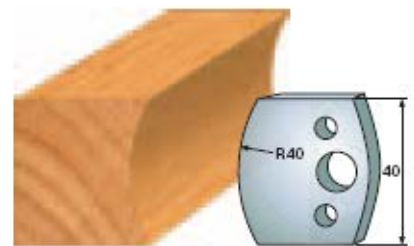

F 87 SP
F 4087 HS
A 87

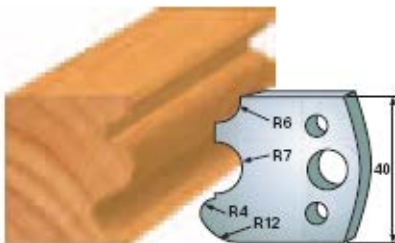

F 88 SP
F 4088 HS
A 88

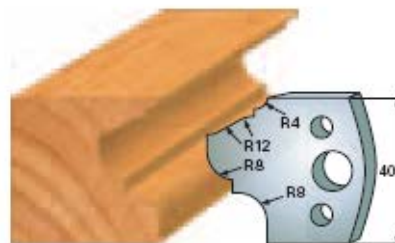

F 89 SP
F 4089 HS
A 89

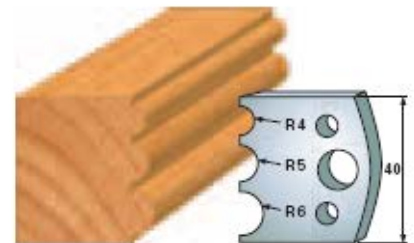

F 90 SP
F 4090 HS
A 90

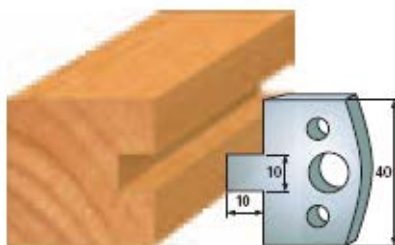

F 91 SP
F 4091 HS
A 91

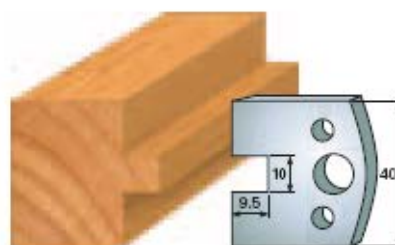

F 92 SP
F 4092 HS
A 92



F 93 SP
F 4093 HS
A 93

Universeel profielmessen

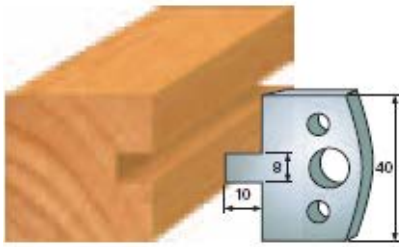

F 94 SP
F 4094 HS
A 94

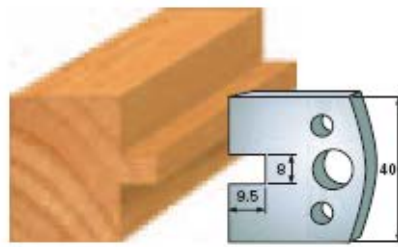

F 95 SP
F 4095 HS
A 95

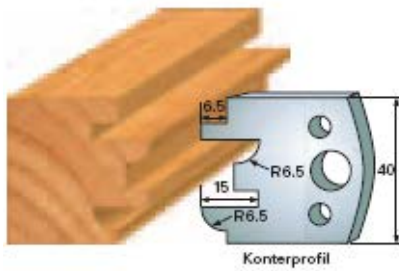

F 96 SP
F 4096 HS
A 96

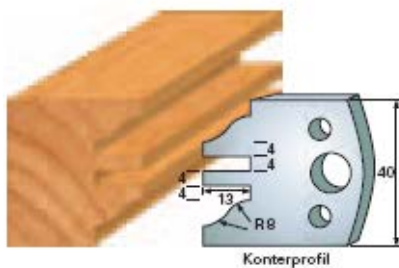

F 97 SP
F 4097 HS
A 97

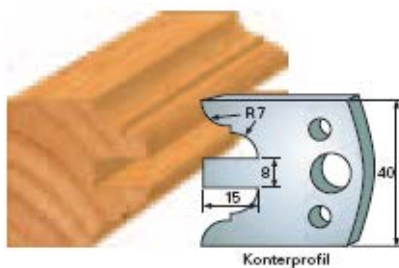

F 98 SP
F 4098 HS
A 98

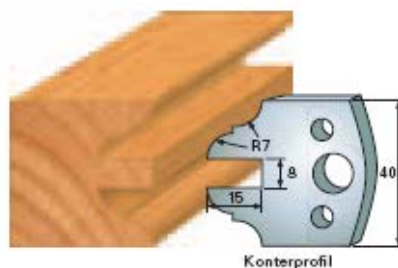

F 99 SP
F 4099 HS
A 99



Universeel profielmessen

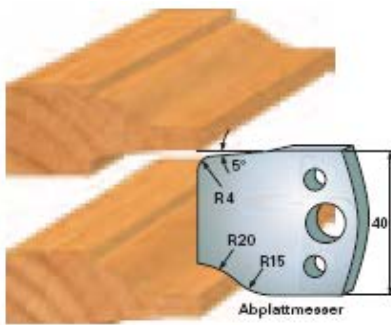

F 100 SP
F 4100 HS
A 100

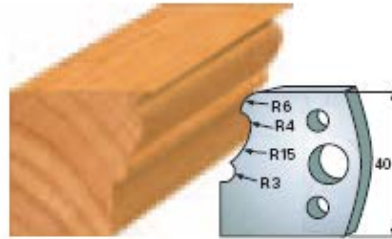

F 101 SP
F 4101 HS
A 101

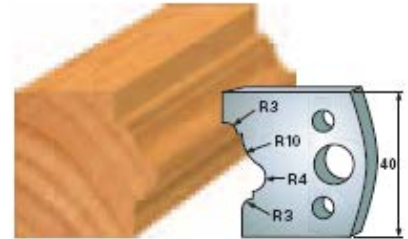

F 102 SP
F 4102 HS
A 102

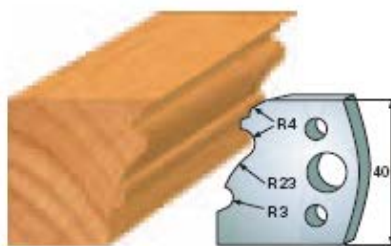

F 103 SP
F 4103 HS
A 103

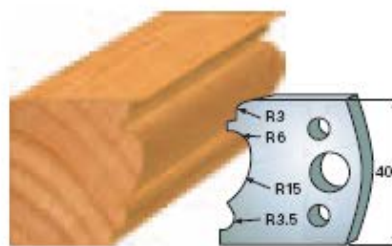

F 104 SP
F 4104 HS
A 104

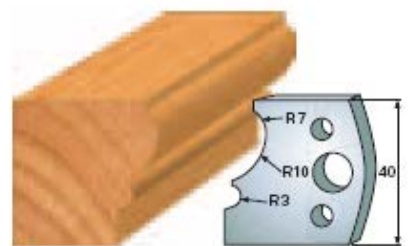

F 105 SP
F 4105 HS
A 105

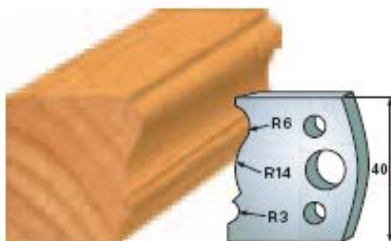

F 106 SP
F 4106 HS
A 106

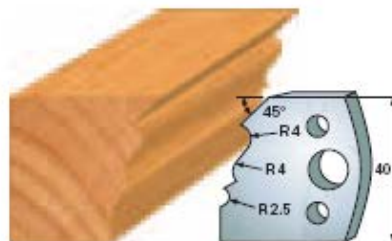

F 107 SP
F 4107 HS
A 107

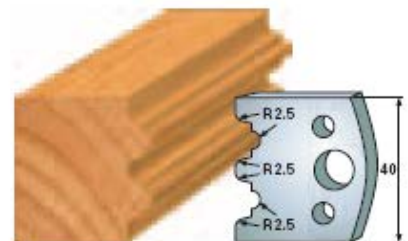

F 108 SP
F 4108 HS
A 108

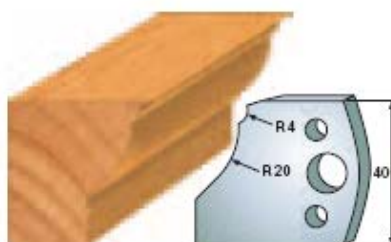

F 109 SP
F 4109 HS
A 109

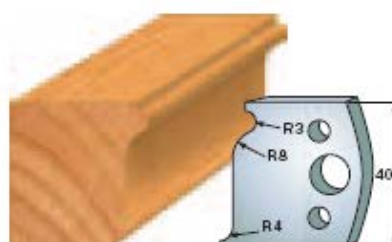

F 110 SP
F 4110 HS
A 110

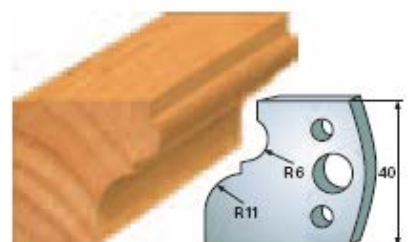

F 111 SP
F 4111 HS
A 111

Universeel profielmessen

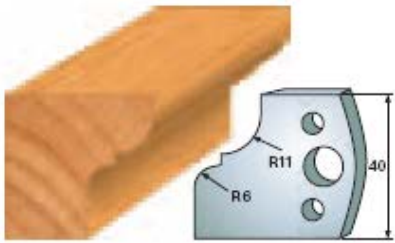

F 112 SP
F 4112 HS
A 112

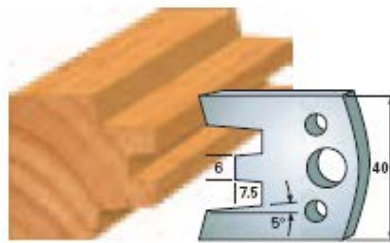

F 113 SP
F 4113 HS
A 113

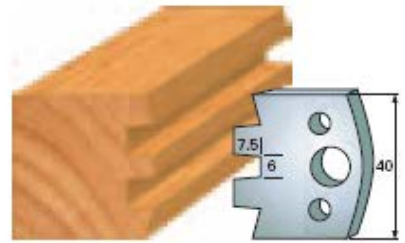

F 114 SP
F 4114 HS
A 114

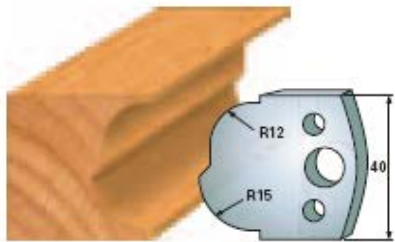

F 115 SP
F 4115 HS
A 115

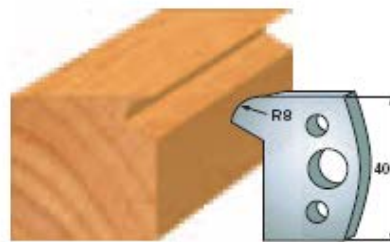

F 116 SP
F 4116 HS
A 116

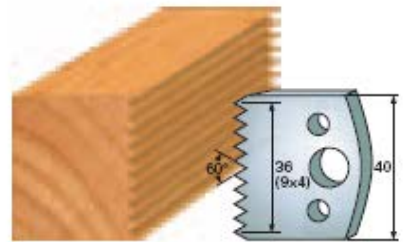

F 117 SP
F 4117 HS
A 117



F 118 SP
F 4118 HS
A 118

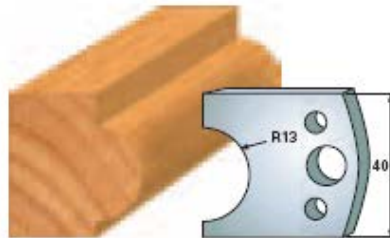

F 119 SP
F 4119 HS
A 119

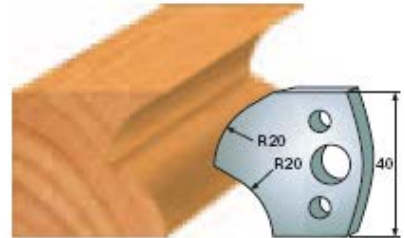

F 120 SP
F 4120 HS
A 120

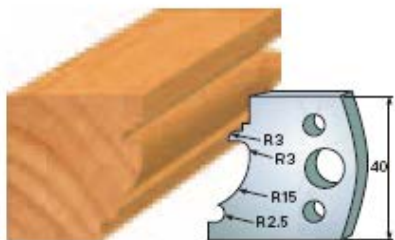

F 121 SP
F 4121 HS
A 121

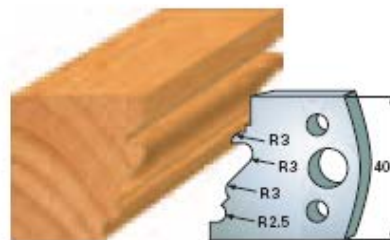

F 122 SP
F 4122 HS
A 122

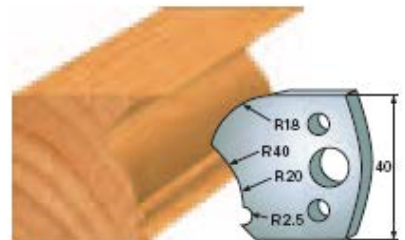

F 123 SP
F 4123 HS
A 123

Universeel profielmessen

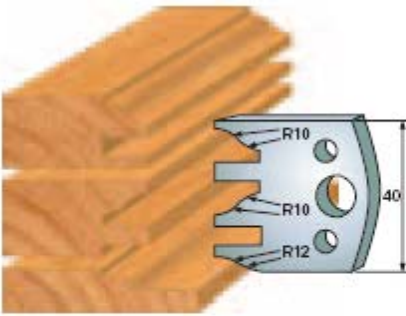

F 124 SP
F 4124 HS
A 124

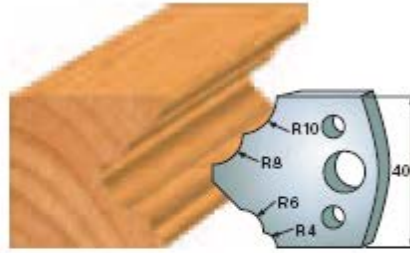

F 125 SP
F 4125 HS
A 125

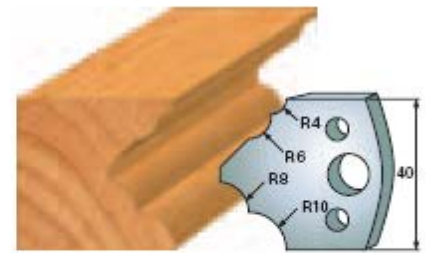

F 126 SP
F 4126 HS
A 126

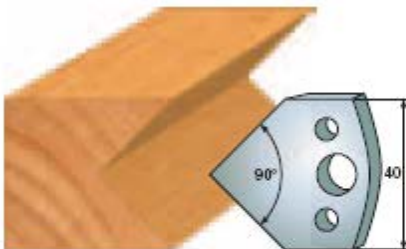

F 127 SP
F 4127 HS
A 127

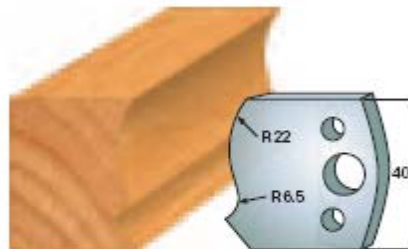

F 128 SP
F 4128 HS
A 128

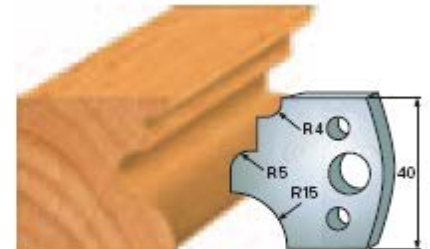

F 129 SP
F 4129 HS
A 129

Universeel profielmessen

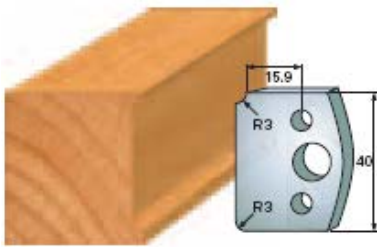

F 170 SP
F 4170 HS
A 170

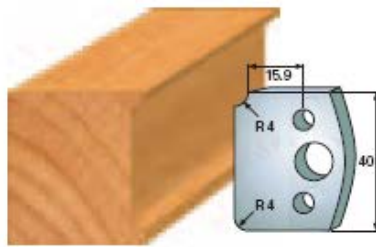

F 171 SP
F 4171 HS
A 171

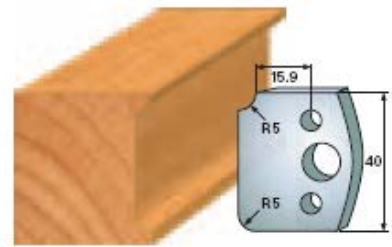

F 172 SP
F 4172 HS
A 172

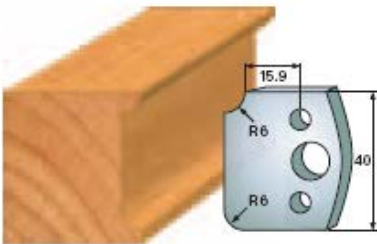

F 173 SP
F 4173 HS
A 173

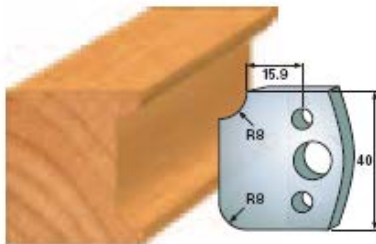

F 174 SP
F 4174 HS
A 174

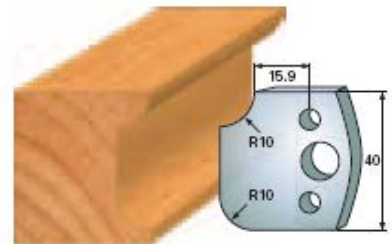

F 175 SP
F 4175 HS
A 175

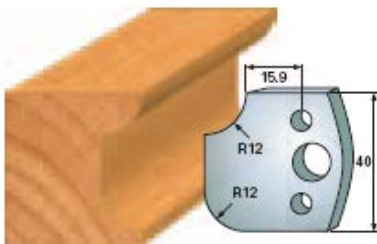

F 176 SP
F 4176 HS
A 176

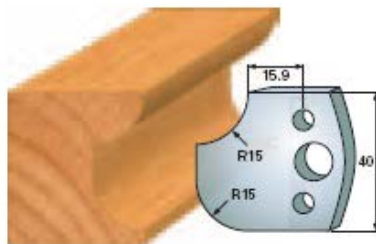

F 177 SP
F 4177 HS
A 177

Universeel profielmessen

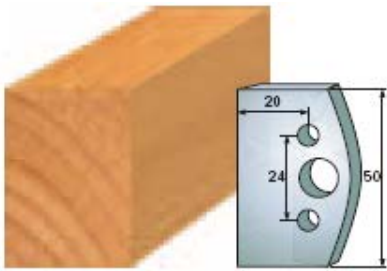

F 500 SP
F 5500 HS
A 500

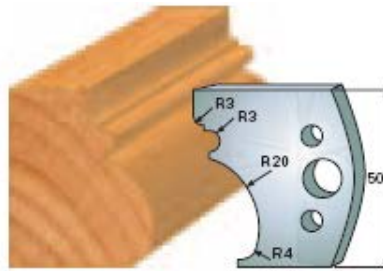

F 501 SP
F 5501 HS
A 501

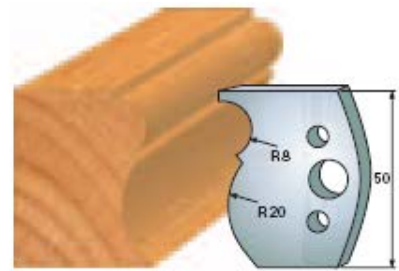

F 502 SP
F 5502 HS
A 502

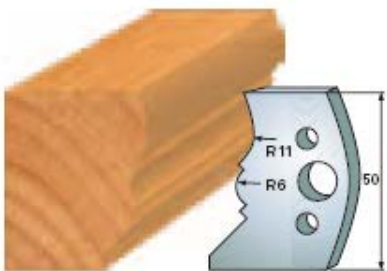

F 503 SP
F 5503 HS
A 503

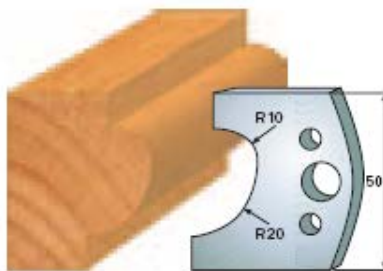

F 504 SP
F 5504 HS
A 504

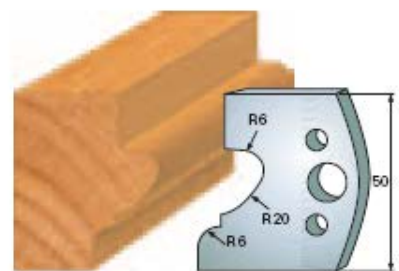

F 505 SP
F 5505 HS
A 505

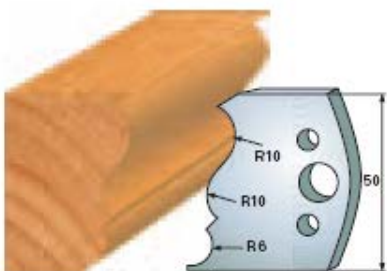

F 506 SP
F 5506 HS
A 506



F 507 SP
F 5507 HS
A 507

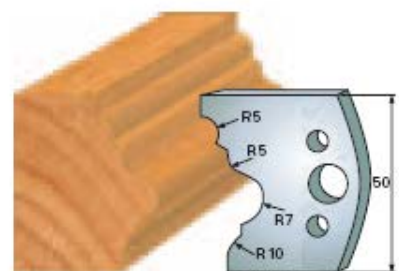

F 508 SP
F 5508 HS
A 508

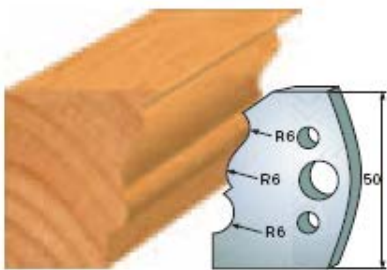

F 509 SP
F 5509 HS
A 509

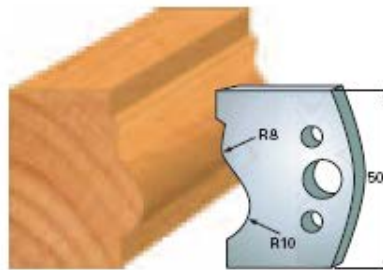

F 510 SP
F 5510 HS
A 510

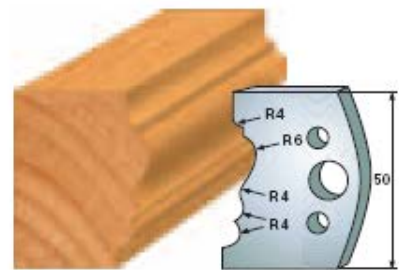

F 511 SP
F 5511 HS
A 511

Universeel profielmessen

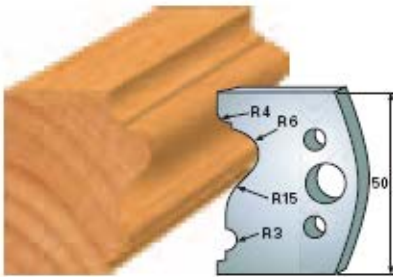

F 512 SP
F 5512 HS
A 512

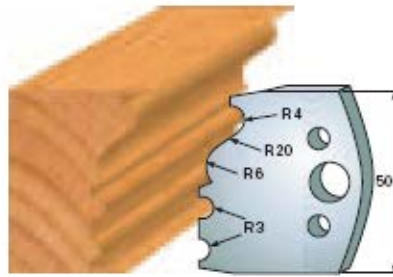

F 513 SP
F 5513 HS
A 513

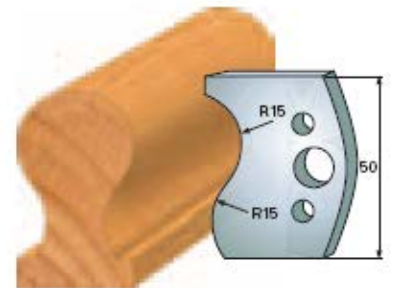

F 514 SP
F 5514 HS
A 514

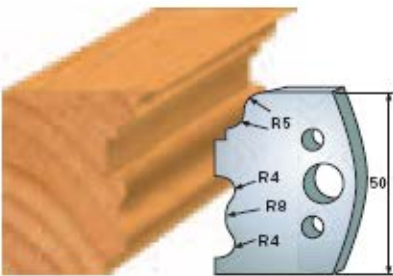

F 515 SP
F 5515 HS
A 515

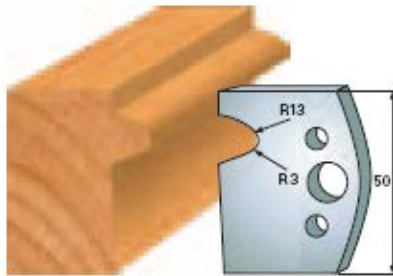

F 516 SP
F 5516 HS
A 516

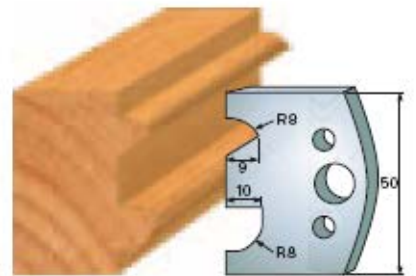

F 517 SP
F 5517 HS
A 517

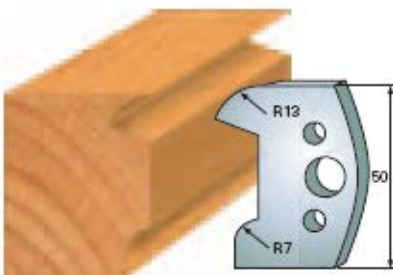

F 518 SP
F 5518 HS
A 518

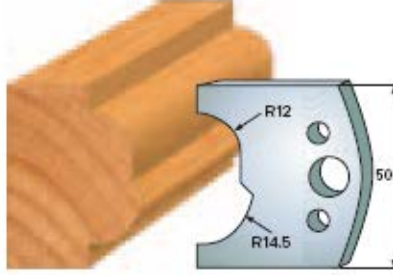

F 519 SP
F 5519 HS
A 519

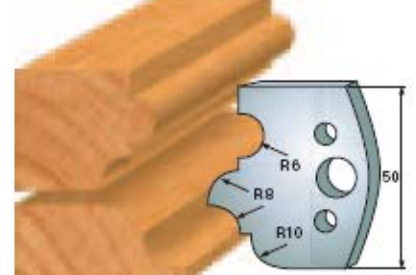

F 520 SP
F 5520 HS
A 520

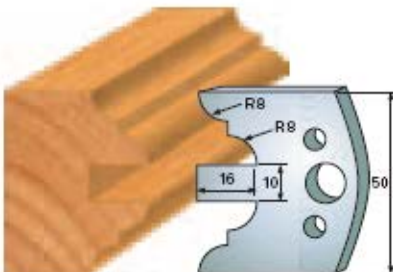

F 522 SP
F 5522 HS
A 522

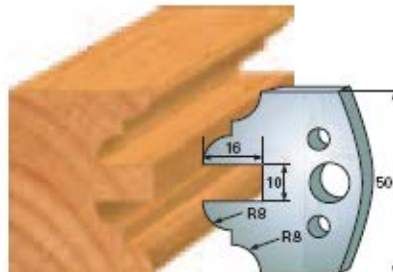

F 523 SP
F 5523 HS
A 523



Universeel profielmessen

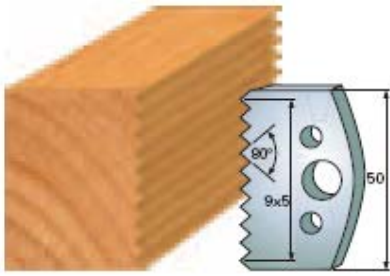

F 524 SP
F 5524 HS
A 524

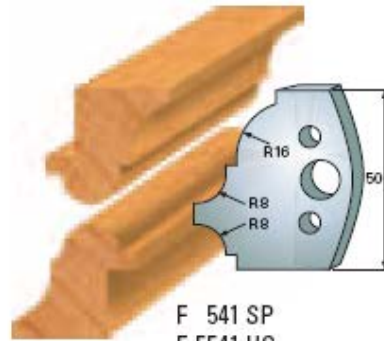

F 541 SP
F 5541 HS
A 541

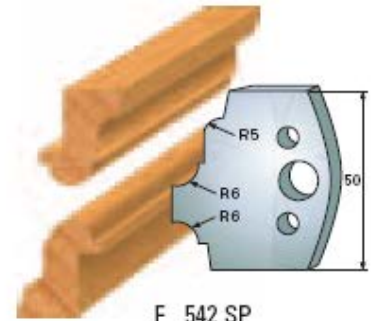

F 542 SP
F 5542 HS
A 542

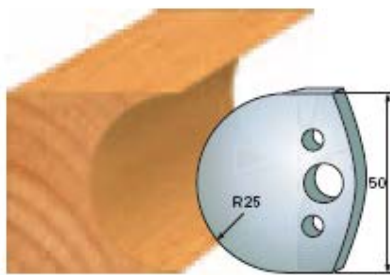

F 543 SP
F 5543 HS
A 543

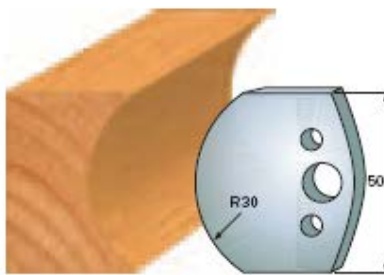

F 544 SP
F 5544 HS
A 544

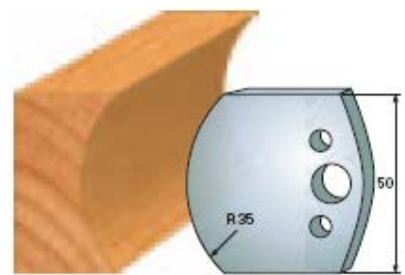

F 545 SP
F 5545 HS
A 545

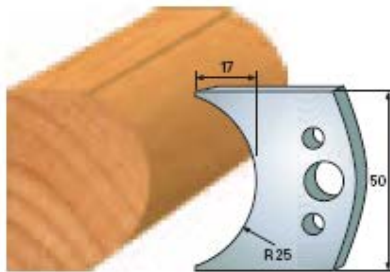

F 546 SP
F 5546 HS
A 546



F 547 SP
F 5547 HS
A 547



F 548 SP
F 5548 HS
A 548

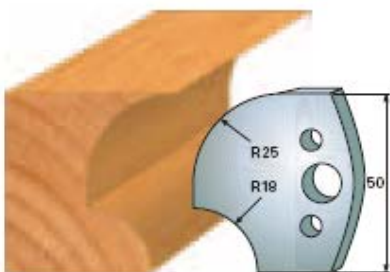

F 549 SP
F 5549 HS
A 549

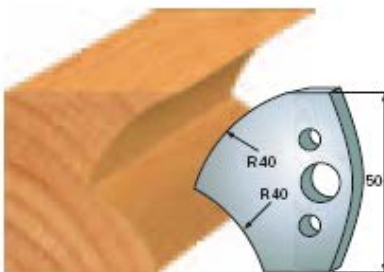

F 550 SP
F 5550 HS
A 550

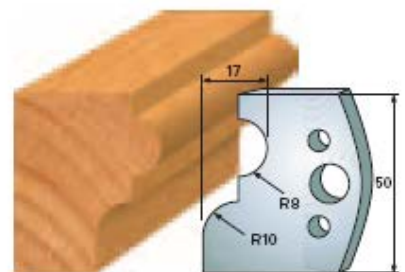

F 551 SP
F 5551 HS
A 551

Universeel profielmessen

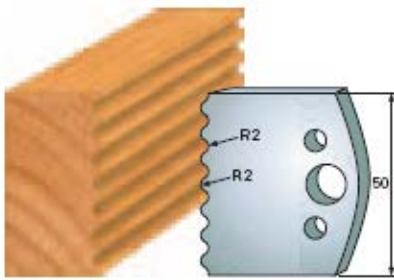

F 552 SP
F 5552 HS
A 552

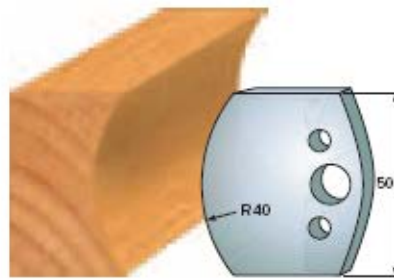

F 553 SP
F 5553 HS
A 553

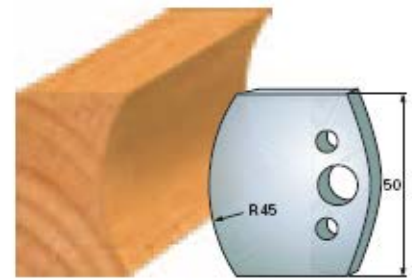

F 554 SP
F 5554 HS
A 554



F 555 SP
F 5555 HS
A 555



F 556 SP
F 5556 HS
A 556

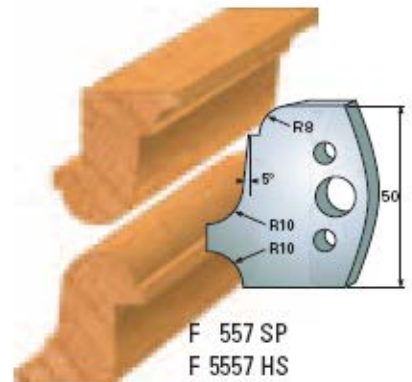

F 557 SP
F 5557 HS
A 557

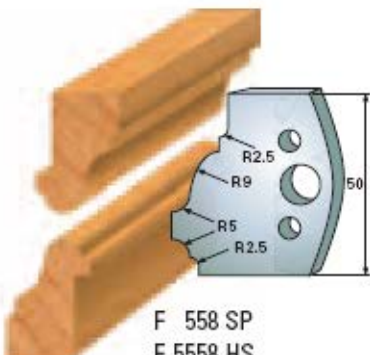

F 558 SP
F 5558 HS
A 558

Universeel profielmessen



F 559 SP
F 5559 HS
A 559

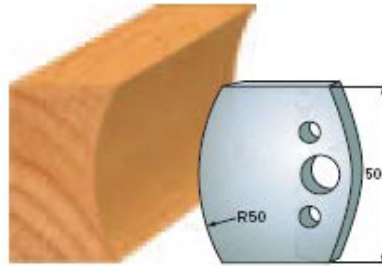

F 560 SP
F 5560 HS
A 560

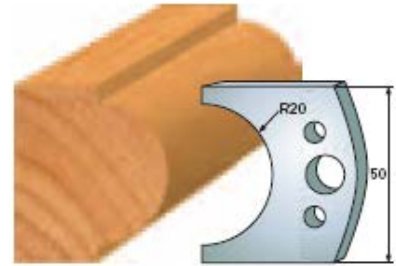

F 561 SP
F 5561 HS
A 561

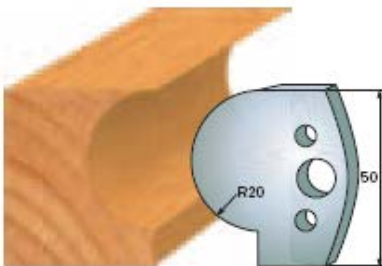

F 562 SP
F 5562 HS
A 562

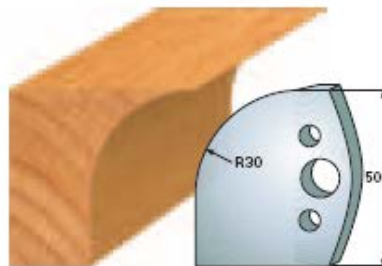

F 563 SP
F 5563 HS
A 563

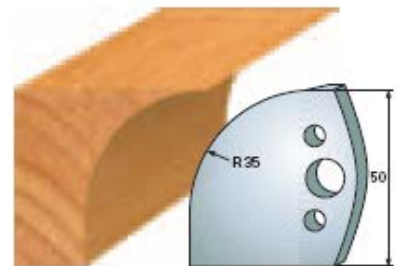

F 564 SP
F 5564 HS
A 564

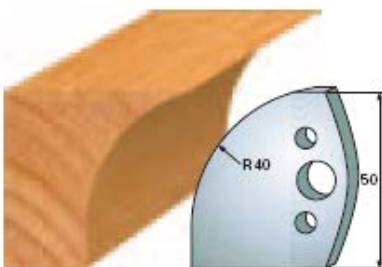

F 565 SP
F 5565 HS
A 565

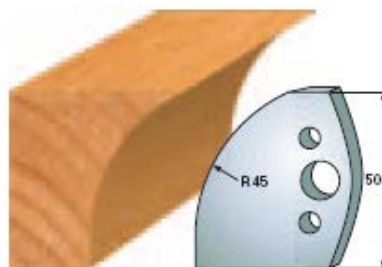

F 566 SP
F 5566 HS
A 566

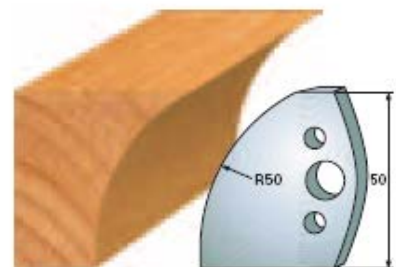

F 567 SP
F 5567 HS
A 567

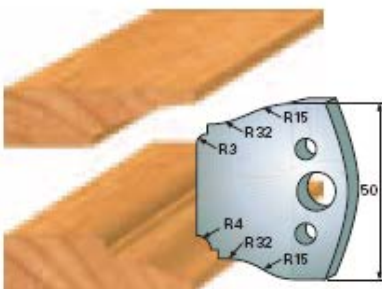

F 568 SP
F 5568 HS
A 568

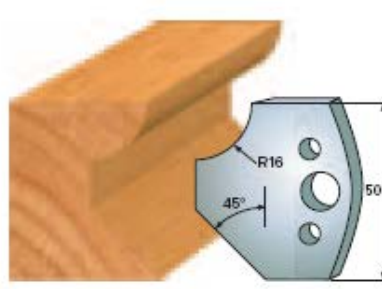

F 569 SP
F 5569 HS
A 569

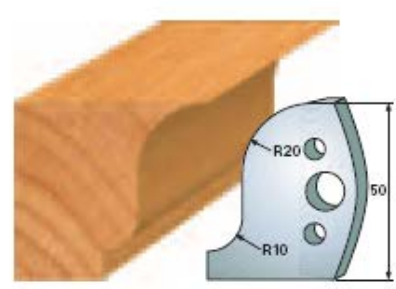

F 570 SP
F 5570 HS
A 570

Universeel profielmessen

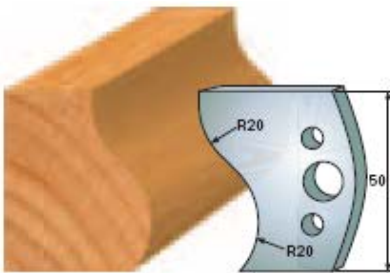

F 571 SP
F 5571 HS
A 571

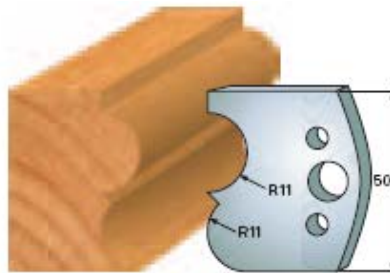

F 572 SP
F 5572 HS
A 572

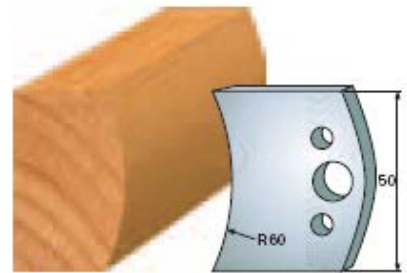

F 573 SP
F 5573 HS
A 573

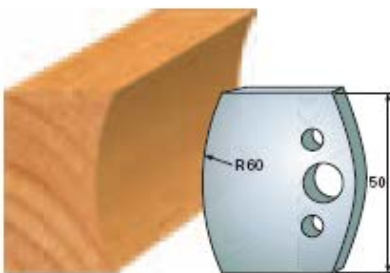

F 574 SP
F 5574 HS
A 574

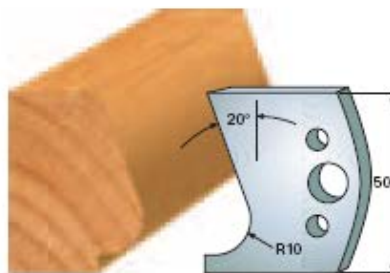

F 575 SP
F 5575 HS
A 575

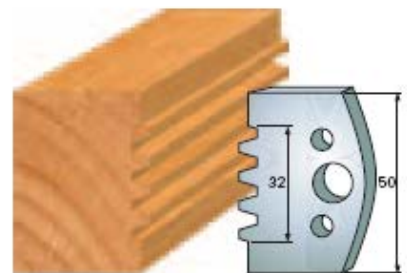

F 576 SP
F 5576 HS
A 576

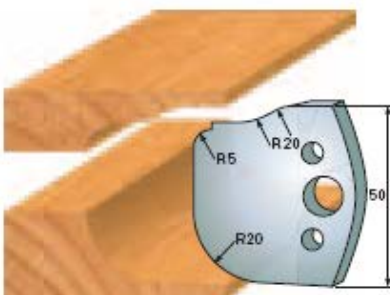

F 577 SP
F 5577 HS
A 577

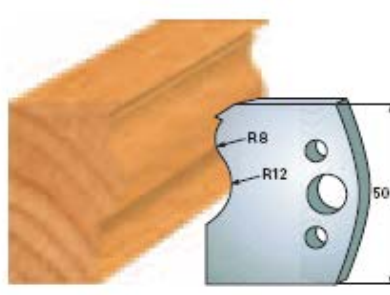

F 578 SP
F 5578 HS
A 578

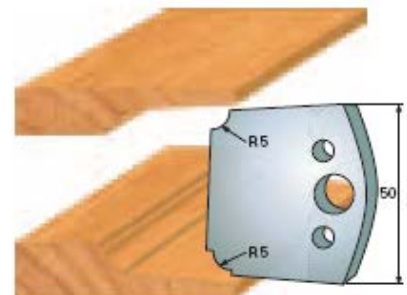

F 579 SP
F 5579 HS
A 579

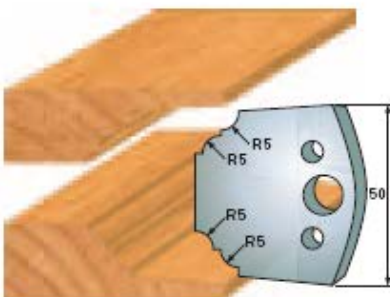

F 580 SP
F 5580 HS
A 580

Universeel profielmessenkop

Aluminium freesbody

Artikel-Nummer item no./sam. art.	∅ TD (mm)	B (mm)	d (mm)		Z		n min. - max.	
03.120.050.030A	120	50	30 - 50		2		4500 - 6600	

MAN 

Aluminium freesbody

Artikel-Nummer item no./num. art.	∅ TD (mm)	B (mm)	d (mm)		Z	V	n min. - max.	
03.120.050.030A1	118	50	30 - 50		2	1+1	4500 - 6600	

MAN 

Aluminium freesbody

Artikel-Nummer item no./num. art.	∅ TD (mm)	B (mm)	d (mm)		Z	V	n min. - max.	
04.120.050.030A1	118	50	30 - 50		2	1+1	4500 - 6600	

MEC 

Universeel profielfreeset

Man uitvoering met 6 set messen

Artikel-Nummer item no./num. art.	Werkzeug tool/outil	Grundkörper tool body corps de base	Anzahl Profile number of profiles quantité de profils	Profil-Nr. profile numbers num. des profils	
20.HK.03.50.06P/Alu	03.100.050.030.A	Alu/light alloy alliage léger	6	201 – 206	



Man uitvoering met 12 set messen

Artikel-Nummer item no./num. art.	Werkzeug tool/outil	Grundkörper tool body corps de base	Anzahl Profile number of profiles quantité de profils	Profil-Nr. profile numbers num. des profils	
20.HK.03.50.12P/Alu	03.100.050.030.A	Alu/light alloy alliage léger	12	201 – 212	



Man uitvoering met 24 set messen

Artikel-Nummer item no./num. art.	Werkzeug tool/outil	Grundkörper tool body corps de base	Anzahl Profile number of profiles quantité de profils	Profil-Nr. profile numbers num. des profils	
20.HK.03.50.24P/Alu	03.100.050.030.A	Alu/light alloy alliage léger	24	201 – 224	



Universeel profielmessen

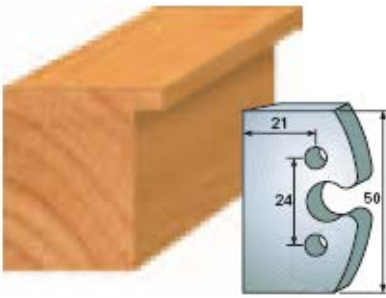

F 200 SP
A 200

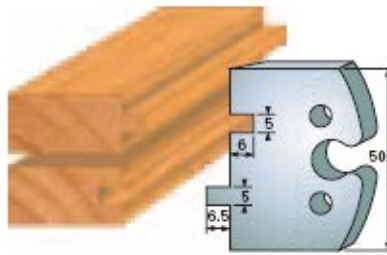

F 201 SP
A 201

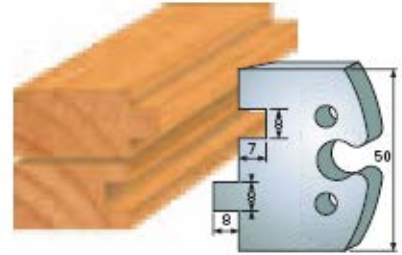

F 202 SP
A 202

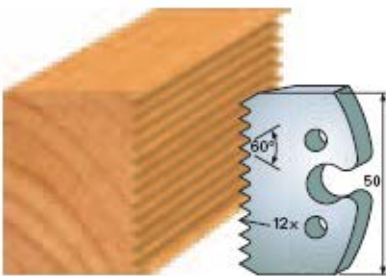

F 203 SP
A 203

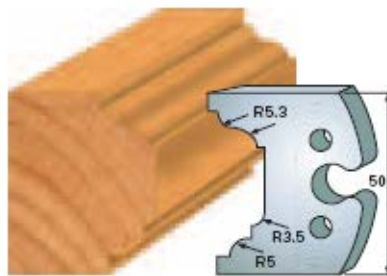

F 204 SP
A 204

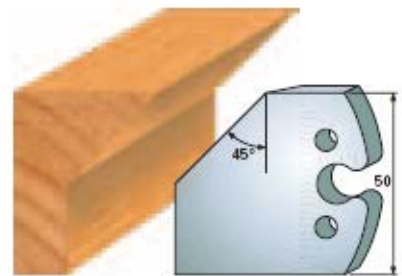

F 205 SP
A 205

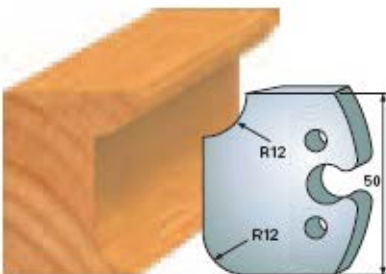

F 206 SP
A 206

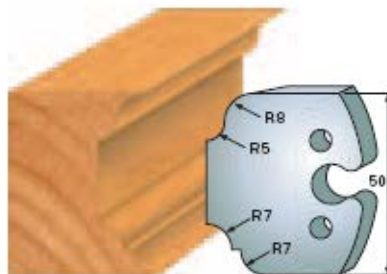

F 207 SP
A 207

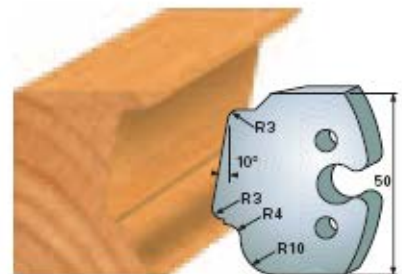

F 208 SP
A 208

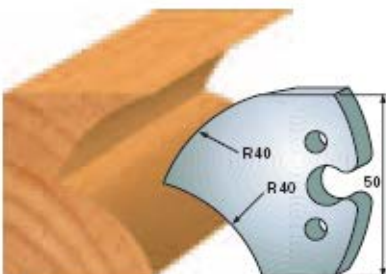

F 209 SP
A 209

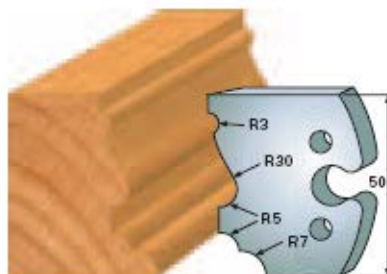

F 210 SP
A 210

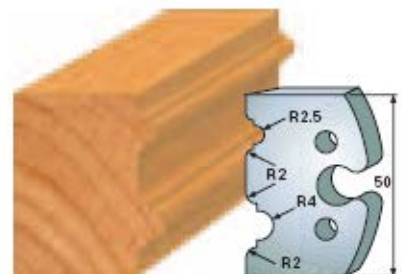

F 211 SP
A 211

Universeel profielmessen

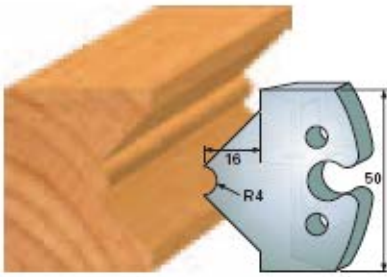

F 212 SP
A 212

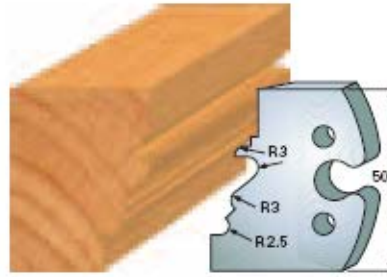

F 213 SP
A 213

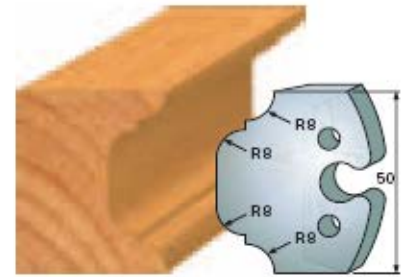

F 214 SP
A 214



F 215 SP
A 215

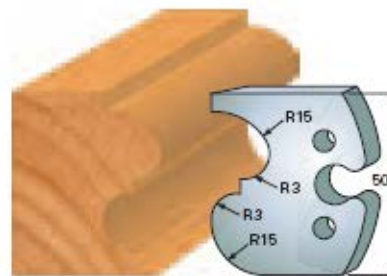

F 216 SP
A 216

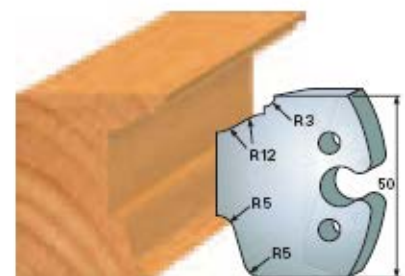

F 217 SP
A 217

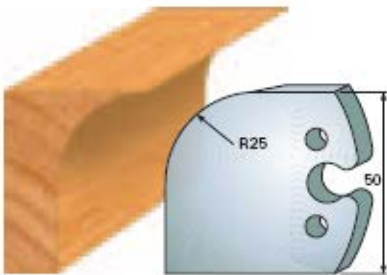

F 218 SP
A 218

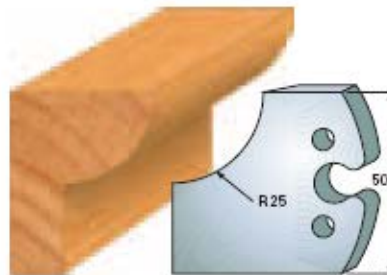

F 219 SP
A 219

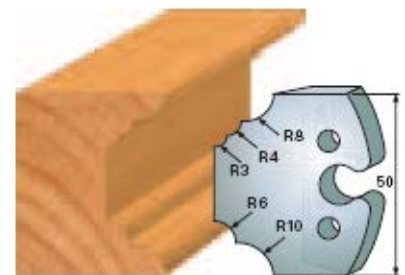

F 220 SP
A 220

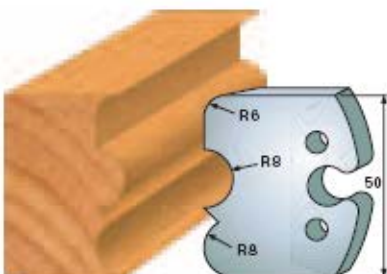

F 221 SP
A 221

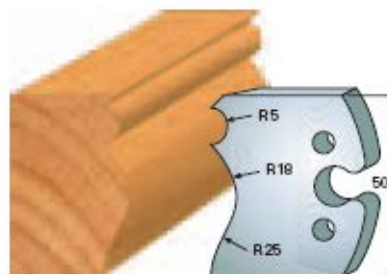

F 222 SP
A 222

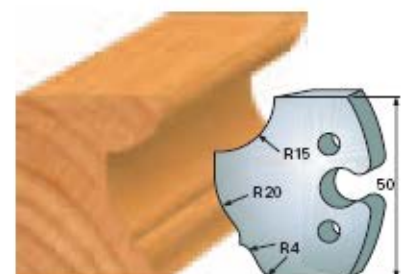

F 223 SP
A 223

Universeel profielmessen

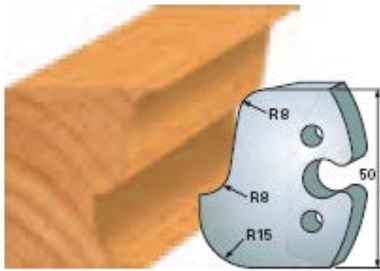

F 224 SP
A 224

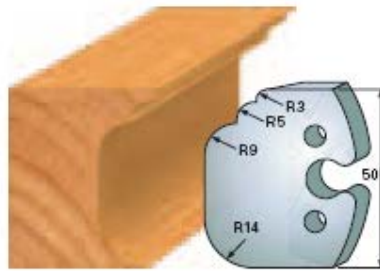

F 225 SP
A 225

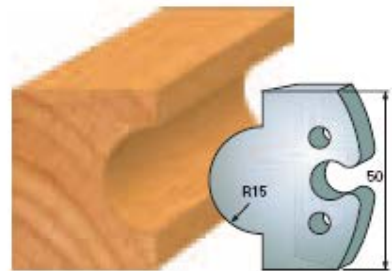

F 226 SP
A 226

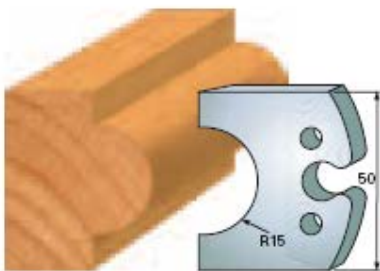

F 227 SP
A 227

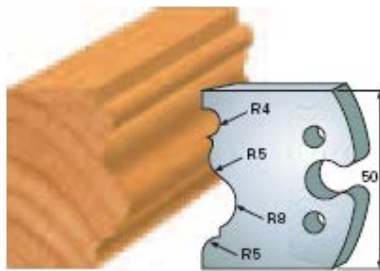

F 228 SP
A 228

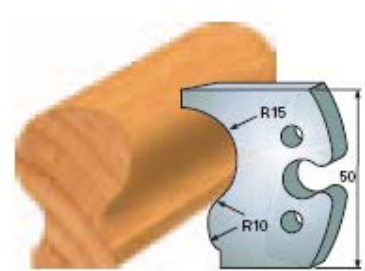

F 229 SP
A 229

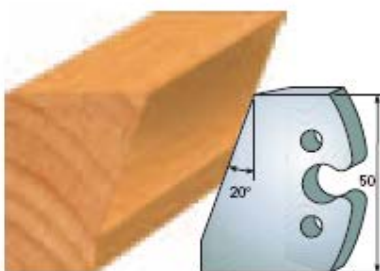

F 230 SP
A 230

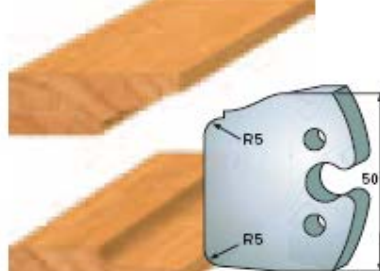

F 231 SP
A 231

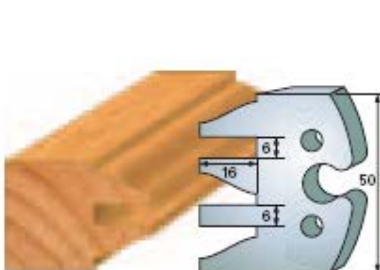

F 232 SP
A 232

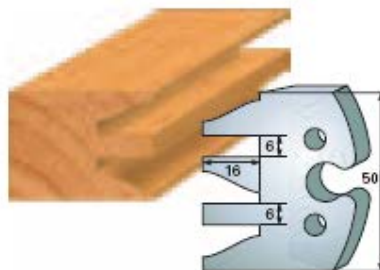

F 232 SP
A 232



Universeel profielmessen

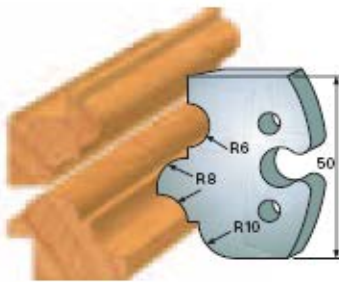

F 233 SP
A 233

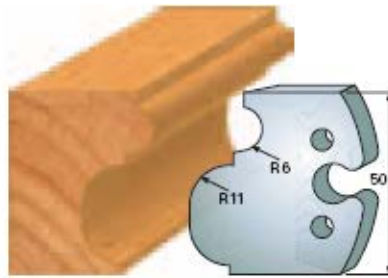

F 234 SP
A 234

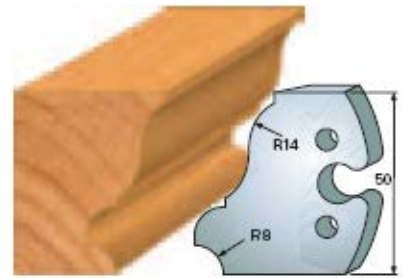

F 235 SP
A 235

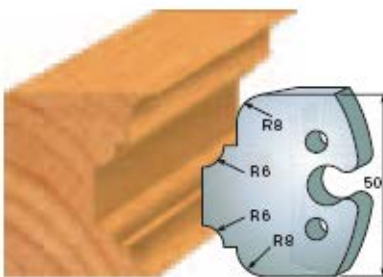

F 236 SP
A 236

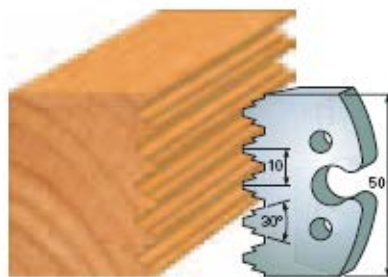

F 237 SP
A 237

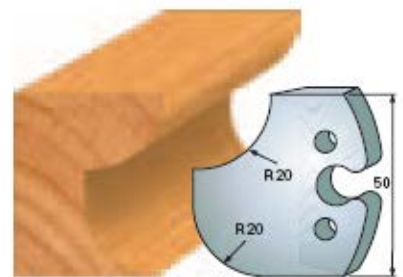

F 238 SP
A 238

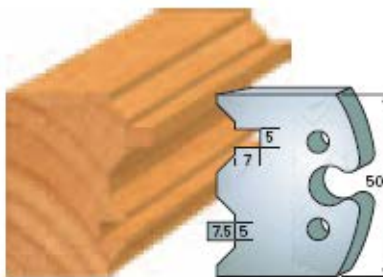

F 239 SP
A 239

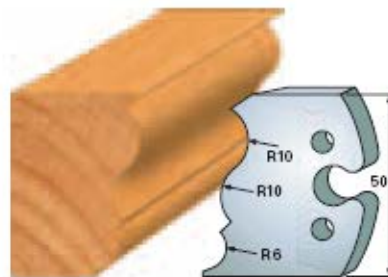

F 240 SP
A 240

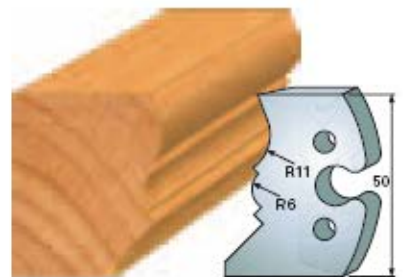

F 241 SP
A 241

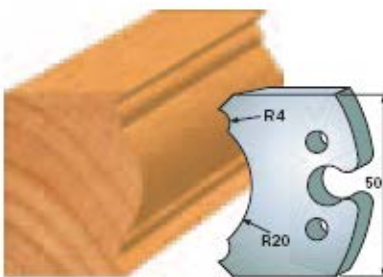

F 242 SP
A 242

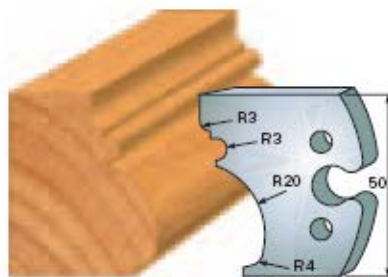

F 243 SP
A 243

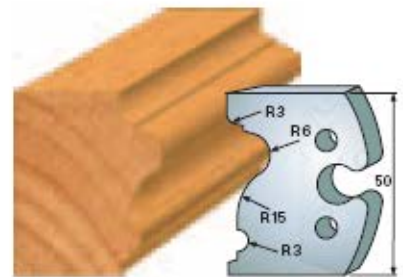

F 244 SP
A 244

Universeel profielmessen

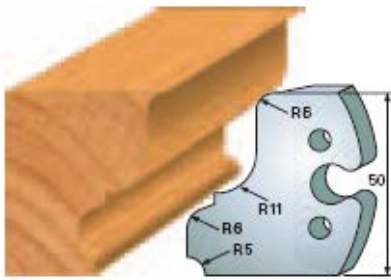

F 245 SP
A 245

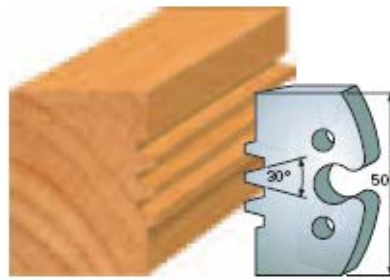

F 246 SP
A 246

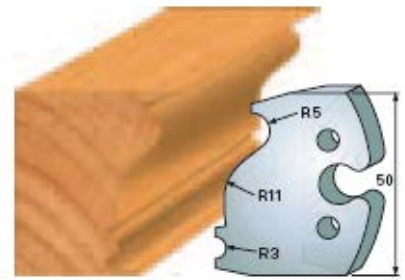

F 247 SP
A 247

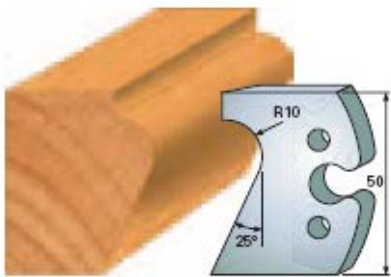

F 248 SP
A 248

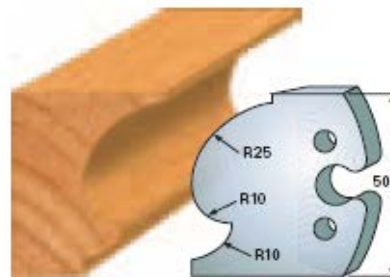

F 249 SP
A 249

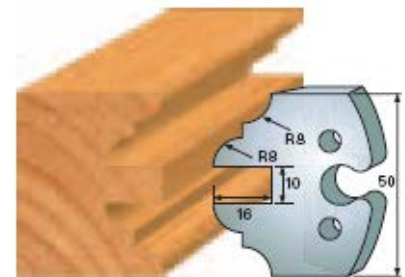

F 250 SP
A 250

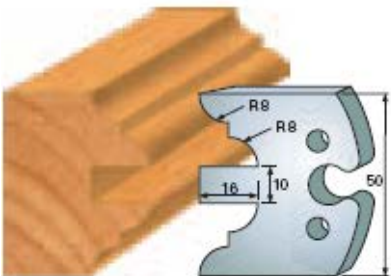

F 251 SP
A 251

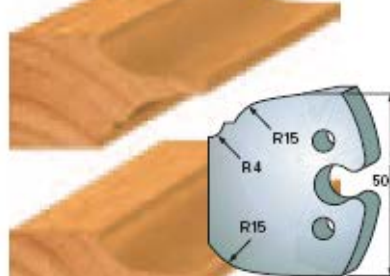

F 252 SP
A 252

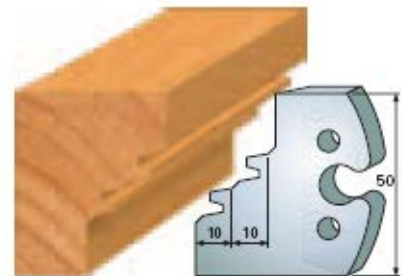

F 253 SP
A 253

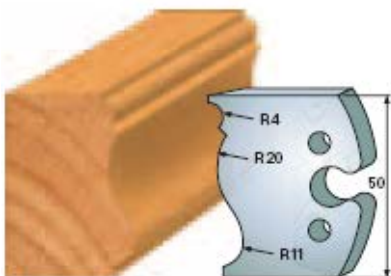

F 254 SP
A 254

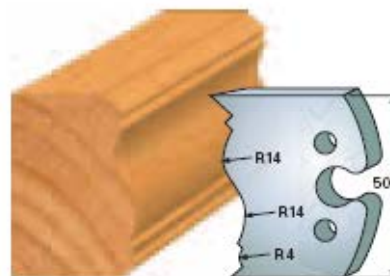

F 255 SP
A 255

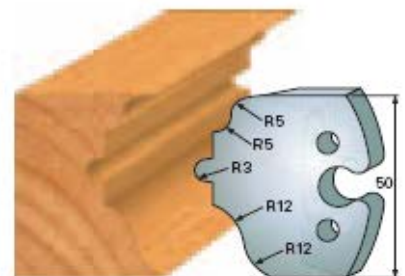

F 256 SP
A 256

Universeel profielmessen

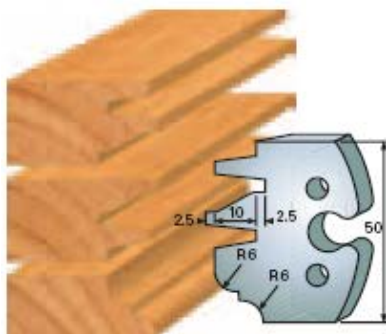

F 257 SP
A 257

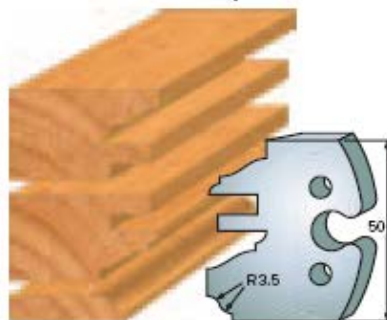

F 258 SP
A 258

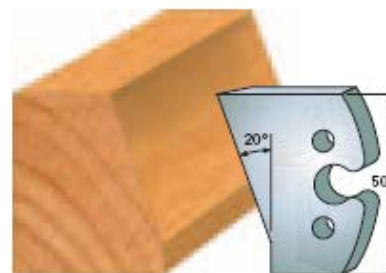

F 259 SP
A 259

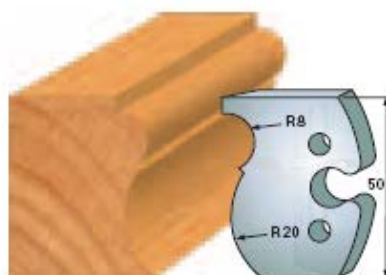

F 260 SP
A 260

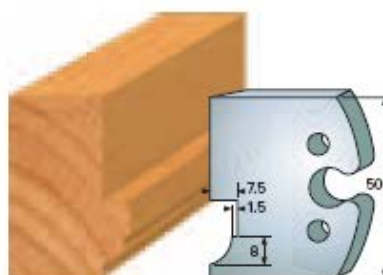

F 261 SP
A 261

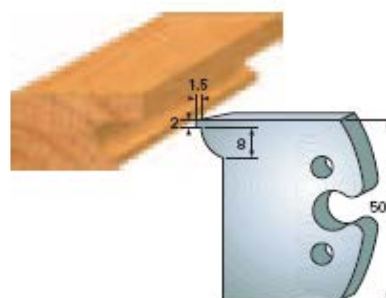

F 262 SP
A 262

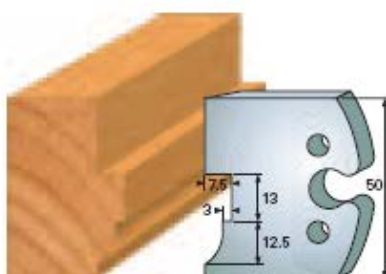

F 263 SP
A 263

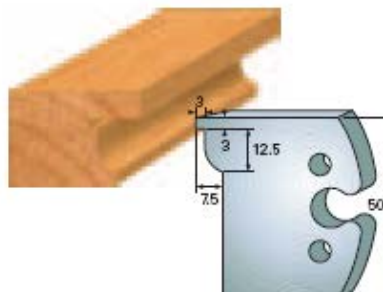

F 264 SP
A 264

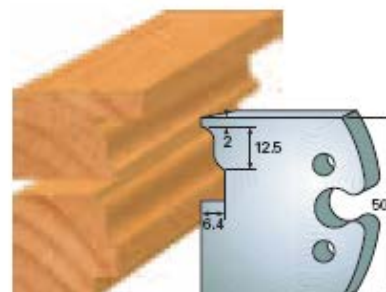

F 265 SP
A 265

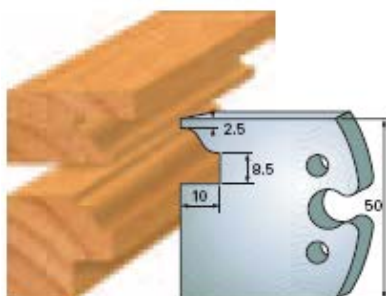

F 266 SP
A 266

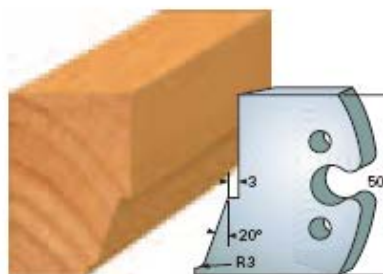

F 267 SP
A 267

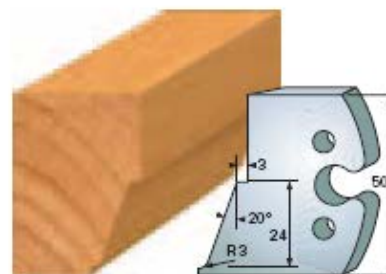

F 268 SP
A 268

Universeel profielmessen

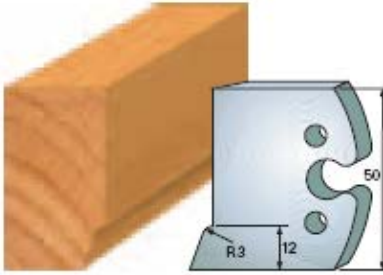

F 269 SP
A 269

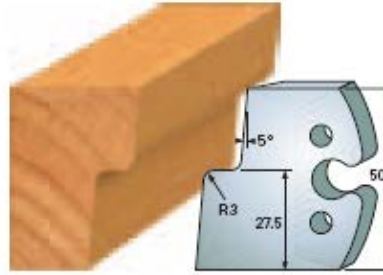

F 270 SP
A 270

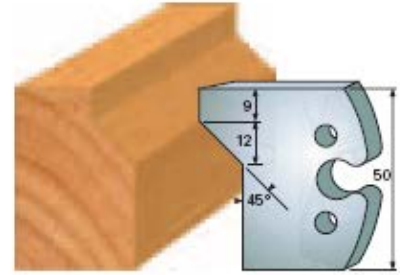

F 271 SP
A 271

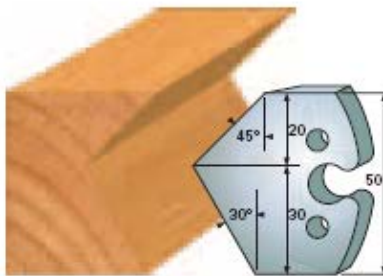

F 272 SP
A 272

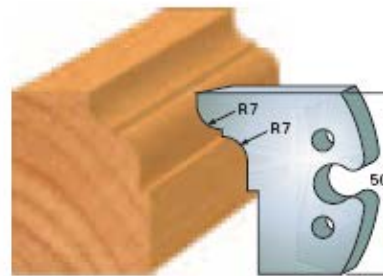

F 273 SP
A 273

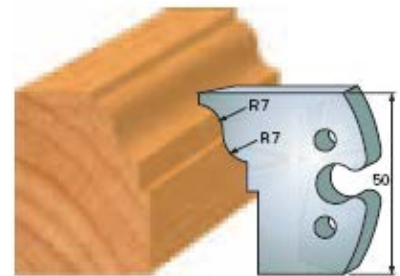

F 274 SP
A 274

Hm groeffrees

D	B	d	Z	COD.
140	4	30	4	K1980430HW
140	5	30	4	K1980530HW
140	6	30	4	K1980630HW
140	8	30	4	K1980830HW
140	10	30	4	K1981030HW
140	12	30	4	K1981230HW
140	14	30	4	K1981430HW
140	15	30	4	K1981530HW
140	16	30	4	K1981630HW
140	18	30	4	K1981830HW
140	20	30	4	K1982030HW



MAN

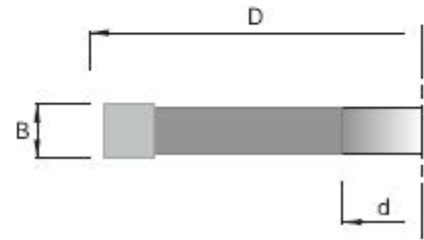

D	B	d	T	Z	V	COD.
160	4 : 7.8	30	30	4	4	K202160430
160	4 : 7.8	40	30	4	4	K202160440
160	7.8 : 15.4	30	30	4	4	K202160730
160	7.8 : 15.4	40	30	4	4	K202160740
160	15.4 : 30.6	30	53	4	4	K202161530
160	15.4 : 30.6	40	48	4	4	K202161540
200	4 : 7.8	30	45	4	4	K202200430
200	4 : 7.8	40	45	4	4	K202200440
200	7.8 : 15.4	30	45	4	4	K202200730
200	7.8 : 15.4	40	45	4	4	K202200740
200	15.4 : 30.6	30	73	4	4	K202201530
200	15.4 : 30.6	40	68	4	4	K202201540

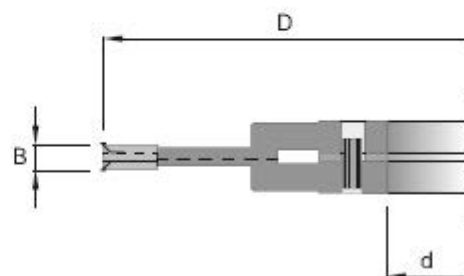
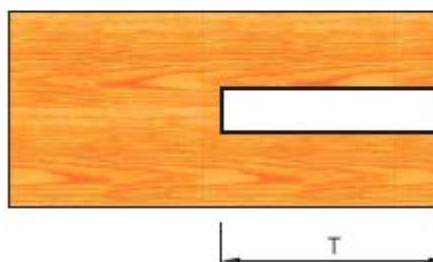

Hm keermes groeffrees

Hm keermes groeffrees

Artikel-Nummer item no./s.nm. art.	Ø D (mm)	B (mm)	d (mm)	t max	Z	V	n min. - max.	
06.100.004.030S2	100	4	30	24	2	2	8000 - 12000	
06.100.005.030S2	100	5	30	24	2	2	8000 - 12000	
06.100.006.030S2	100	6	30	24	2	2	8000 - 12000	



MAN 

Hm keermes groeffrees

Artikel-Nummer item no./s.nm. art.	Ø D (mm)	B (mm)	d (mm)	t max	Z	V	n min. - max.	
06.100.008.030A2	100	8	30	24	2	2	8000 - 12000	
06.100.010.030A2	100	10	30	24	2	2	8000 - 12000	
06.100.012.030A2	100	12	30	24	2	2	8000 - 12000	



MAN 

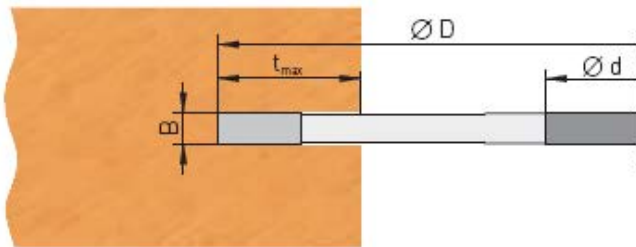

Verstelbare groeffrees

Verstelbare groeffrees met hun keermessen (verstelbaar d.m.v. tussenringen)

Artikel-Nummer item no./num. art.	∅ D (mm)	B (mm)	d (mm)	t max	Z	V	n min. - max.	
01.120.595.030Z4	120	5 - 9,5	30	28	4	4	5000 - 10000	
01.140.595.030Z4	140	5 - 9,5	30	34	4	4	5000 - 8000	
01.150.595.030Z4	150	5 - 9,5	30 - 40	39	4	4	5000 - 8000	

MEC

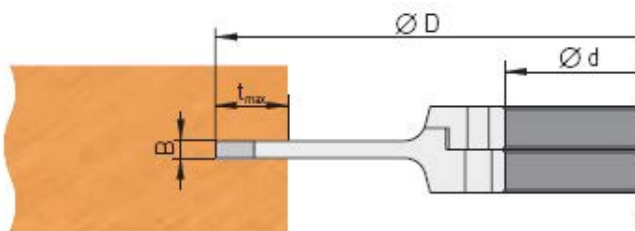

Hm keermes tussenfrees

Artikel-Nummer item no./num. art.	∅ D (mm)	B (mm)	d (mm)		Z		n min. - max.	
01.140.007.030S2	140	7,5	30		2		5000 - 8000	

MEC



Verstelbare groeffrees

Verstelbare groeffrees met hun keernessen (verstelbaar d.m.v. tusseningen)

Z4/V4

Artikel-Nummer item no./num. art.	∅ D (mm)	B (mm)	d (mm)	t max	Z	V	n min. - max.	
01.120.475.030Z4	120	4 - 7,5	30	28	4	4	5000 - 10000	
01.150.475.030Z4	150	4 - 7,5	30	45	4	5000 - 8000		

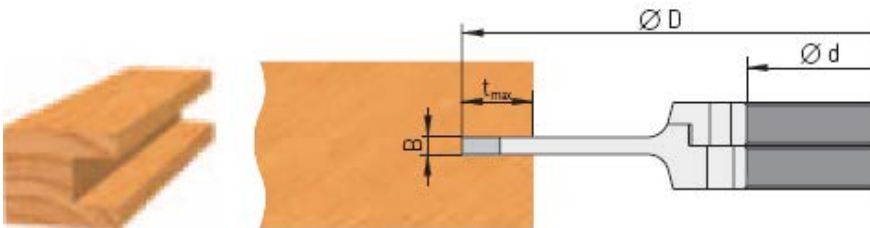

MAN 

Hun keernes tussenfrees

Z2

Artikel-Nummer item no./num. art.	∅ D (mm)	B (mm)	d (mm)		Z		n min. - max.	
01.120.007.030S2	120	7,5	30		2		5000 - 10000	
01.150.007.030S2	150	7,5	30		2		5000 - 3000	



3-delige frees

Z6/V4

Artikel-Nummer item no./num. art.	∅ D (mm)	B (mm)	d (mm)	t max	Z	V	n min. - max.	
01.120.415.030Z6	120	4 - 15	30	28	4 + 2	4	5000 - 10000	
01.150.415.030Z6	150	4 - 15	30	45	4 + 2	4	5000 - 8000	



Kopieerset

Hm keernes kopieerrees

Artikel-Nummer item no./num. art.	∅ D (mm)	B (mm)	d (mm)		Z	n min. - max.	
22.062.060.130.A	62	60	30		10	8000 - 12000	
22.062.080.130.A	62	80	30		12	8000 - 12000	
22.080.080.030.A	80	80	30 - 50		12	8000 - 12000	
22.080.100.030.A	80	100	30 - 50		16	8000 - 12000	
22.080.120.030.A	80	120	30 - 50		18	8000 - 12000	

MAN



Schuurhuls

Artikel-Nummer item no./num. art.	∅ D (mm)	B (mm)	d (mm)			n max.	
09.060.100.030	60	100	30			4500	



Kopieerlager

Artikel-Nummer item no./num. art.	D (mm)	B (mm)	d (mm)		
09.6206-2RSR	62	16	30		
09.6010-2ZR	80	16	50		



Schuin stelbare hoekfrees

Schuin stelbare hoekfrees +/- 45 graden

Artikel-Nummer item no./num. art.	∅ D (mm)	B (mm)	d (mm)	Z	n min. - max.	D max. (45°)
10.120.040.230.A	120	40	30	2	6400 - 8500	138

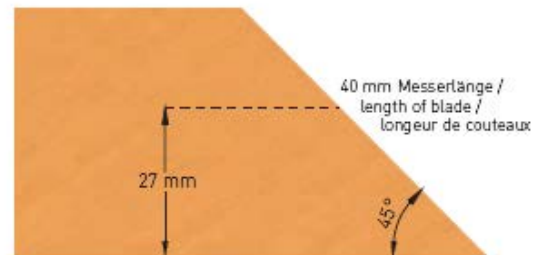
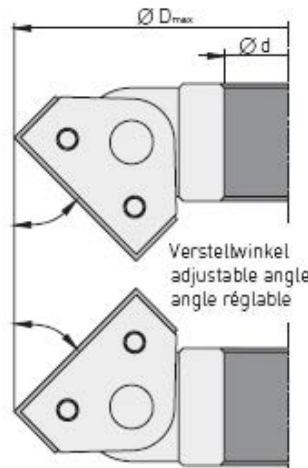
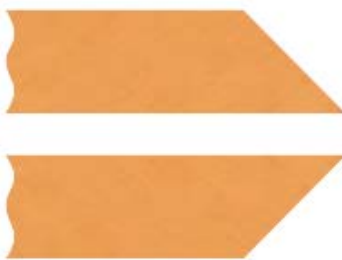
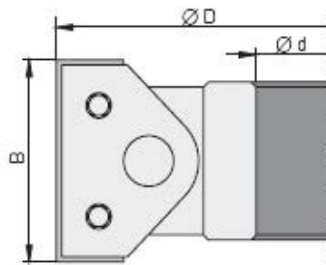

Schijffrees met lun voorsnijder

Artikel-Nummer item no./num. art.	∅ D (mm)	B (mm)	d (mm)	Z	n min. - max.
17.120.006.030.A	120	6,5	30	2	6400 - 8500

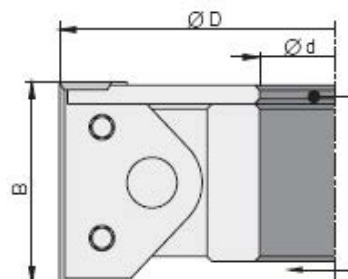

Schuin stelbare hoekfrees

Schuinstelbare hoekfrees +/-90 graden

Artikel-Nummer item no./num. art.	∅ D (mm)	B (mm)	d (mm)	Z	n min. - max.	D max (45°)	
10.150.050.130.S	150	50	30 - 40	2	5900 - 7400	174	
10.160.050.130.S	160	50	30 - 50	2	4800 - 7200	184	
10.160.060.130.S	160	60	30 - 35	2	4800 - 6000	191	
10.170.050.130.S	170	50	30 - 50	2	4500 - 6900	194	
10.170.060.130.S	170	60	30 - 40	2	4500 - 6000	201	

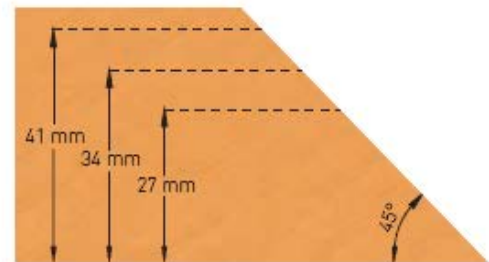
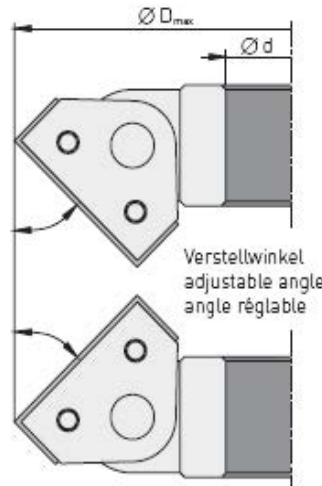
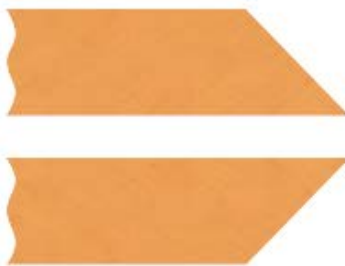
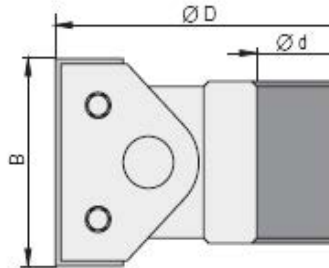

Schijffrees met Hlm voorsnijder

Artikel-Nummer item no./num. art.	∅ D (mm)	B (mm)	d (mm)	Z	n min. - max.	zu Artikel for item/pour art.	
17.150.008.030.S	150	8	30 - 40	2	5900 - 7400	10.150.050.130.S	
17.160.008.030.S	160	8	30 - 50	2	4800 - 7200	10.160.050.130.S	
17.170.008.030.S	170	8	30 - 50	2	4500 - 6900	10.170.050.130.S	

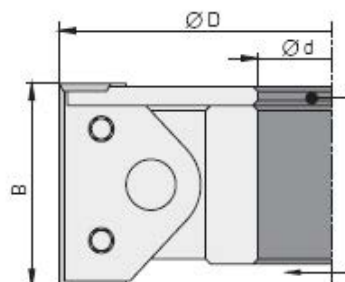

Verlijmfrees

Verlijmfrees met lun keermessen

Artikel-Nummer item no./num. art	Ø f (mm)	B (mm)	d (mm)		z	HW-Profilmesser TC profile knife plaquette profilée HW	n min. - max.
18130.050.030S2	130	50	30 - 50		2	09.1850	5500 - 9000
18130.060.030S2	130	60	30 - 50		2	09.1830	5500 - 9000
18130.080.030S2	130	80	30 - 50		2	09.1830	5500 - 9000
18140.050.030S2	140	50	30 - 50		2	09.1850	5400 - 8000
18140.060.030S2	140	60	30 - 50		2	09.1830	5400 - 8000

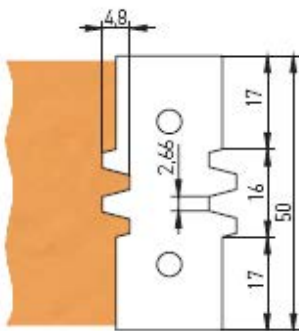
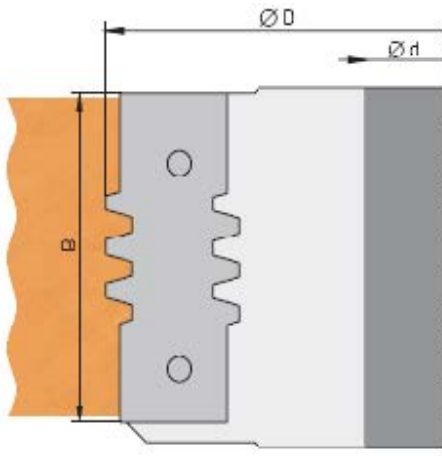

Art.-Nr./item no./num. art. 09.1850

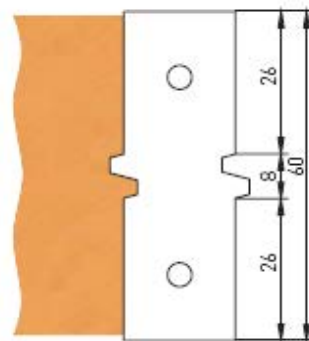

Art.-Nr./item no./num. art. 09.1861

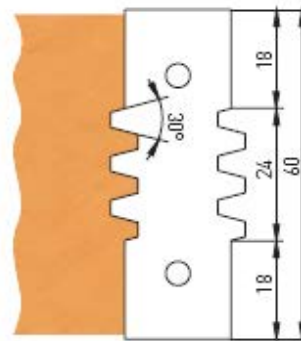

Art.-Nr./item no./num. art. 09.1860

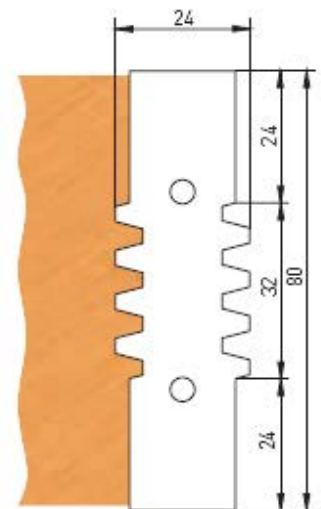

Art.-Nr./item no./num. art. 09.1880

Hoekverlijmfrees

45 graden hoekverlijmfrees met hun keermessen

Artikel-Nummer item no./num. art.	Ø D (mm)	B (mm)	d (mm)	Z	n min. - max.
18.140.040.030A2	140	40	30	2	5500 - 10000

MAN

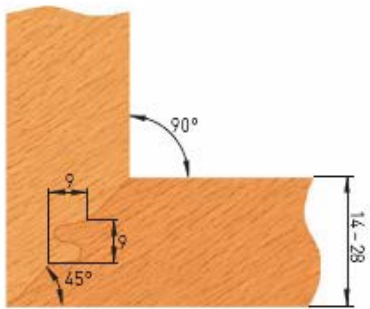
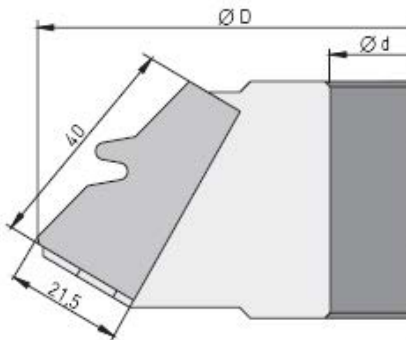

Profiel / contra profielfrees

Hm keernes profiel / contra profielfrees

Artikel-Nummer item no./num. art.	∅ D (mm)	B (mm)	d (mm)		Z	n min. - max.	
12.120.040.030.A	120	40	30 - 40		2	6400 - 8400	

MAN 

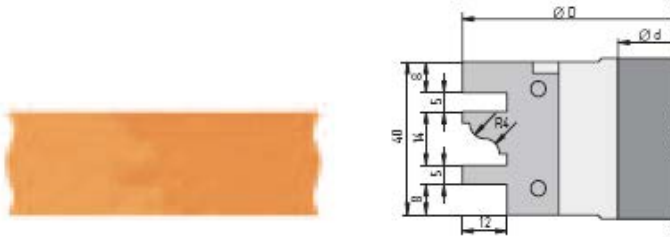

Art.-Nr./item no./num. art. **09.1201**
Abmessung/dimensions/dimensions 40 x 26 x 2 mm



Art.-Nr./item no./num. art. **09.1202**
Abmessung/dimensions/dimensions 40 x 26 x 2 mm



Art.-Nr./item no./num. art. **09.1203**
Abmessung/dimensions/dimensions 40 x 26 x 2 mm



Art.-Nr./item no./num. art. **09.1204**
Abmessung/dimensions/dimensions 40 x 26 x 2 mm

Panelenfrees

Hm keermes panelenfrees bovendraaiend profiel 1

Artikel-Nummer item no./num. art.	∅ D (mm)	B (mm)	d (mm)		Z		n min. - max.
11.160.020.430.A	160	20	30		2		4800 - 8000



Hm keermes panelenfrees bovendraaiend profiel 2

Artikel-Nummer item no./num. art.	∅ D (mm)	B (mm)	d (mm)		Z		n min. - max.
11.160.020.530.A	160	20	30		2		4800 - 8000

Hm keermes panelenfrees bovendraaiend profiel 3

Artikel-Nummer item no./num. art.	∅ D (mm)	B (mm)	d (mm)		Z		n min. - max.
11.160.020.630.A	160	20	30		2		4800 - 8000

MAN

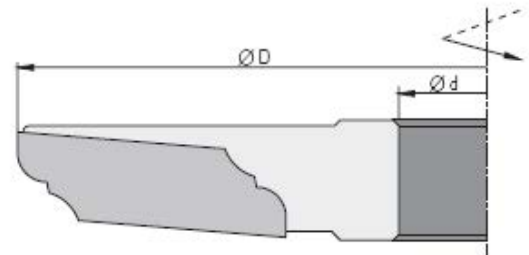

Hm profielmessen

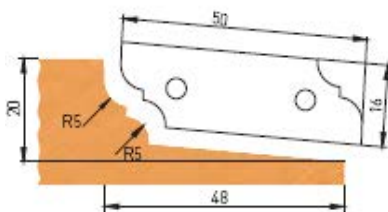

PROFILE NR. 1 / profile number 1 / numéro de profil 1
Art.-Nr./item no./num. art. 09.1101

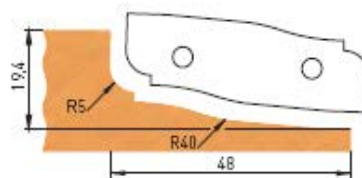

PROFILE NR. 2 / profile number 2 / numéro de profil 2
Art.-Nr./item no./num. art. 09.1102

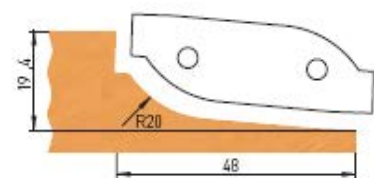

PROFILE NR. 3 / profile number 3 / numéro de profil 3
Art.-Nr./item no./num. art. 09.1103

Panelenfrees

Hm keernes panelenfrees bovendraaiend

Artikel-Nummer item no./num. art.	Ø D (mm)	B (mm)	d (mm)	Z	n min. - max.
11.180.025.030.A	180	25	30 - 50	2	4200 - 7000

MAN 

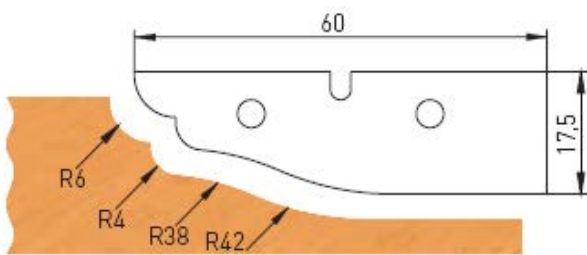
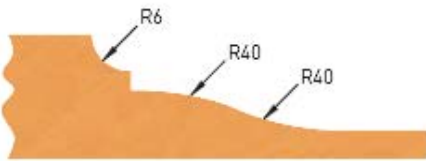
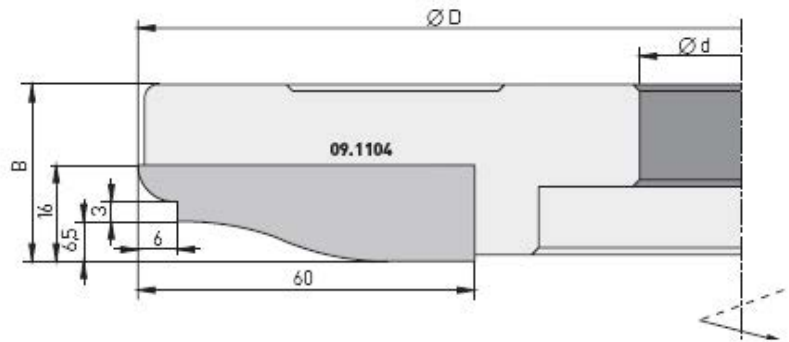

Art.-Nr./item no./num. art. (unten/below/en bas) 09.1130

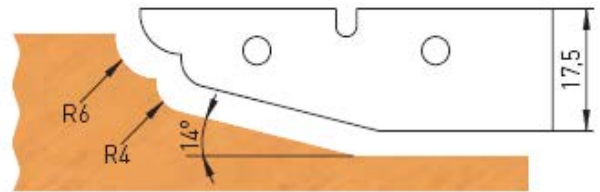

Art.-Nr./item no./num. art. (unten/below/en bas) 09.1131

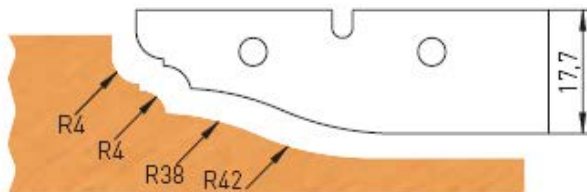

Art.-Nr./item no./num. art. (unten/below/en bas) 09.1132

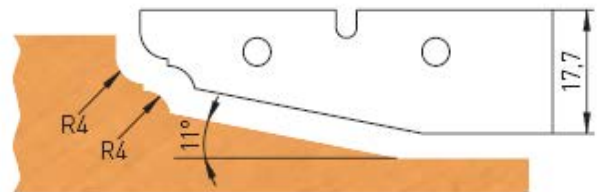

Art.-Nr./item no./num. art. (unten/below/en bas) 09.1133

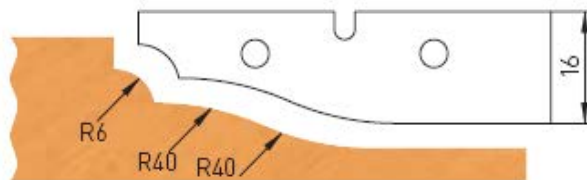

Art.-Nr./item no./num. art. (unten/below/en bas) 09.1134

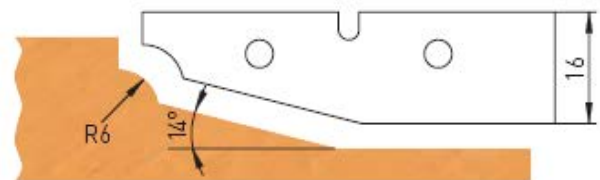

Art.-Nr./item no./num. art. (unten/below/en bas) 09.1135

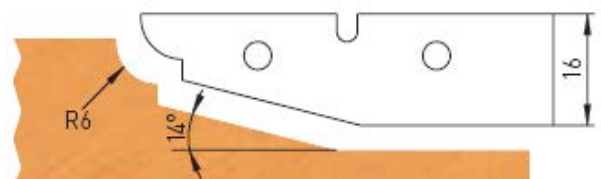

Art.-Nr./item no./num. art. (unten/below/en bas) 09.1136

Hm keermes afrondfrees

Hm keermes afrondfrees

Artikel-Nummer item no./num. art.	∅ D (mm)	B (mm)	d (mm)	Z	Radius radius/rayon	n min. - max.	
19.140.025.130.A	140	32	30 - 40	2	2, 3, 5	5400 - 8800	
19.180.050.130.A	180	50	30 - 50	2	4, 6, 8, 10	4500 - 7500	

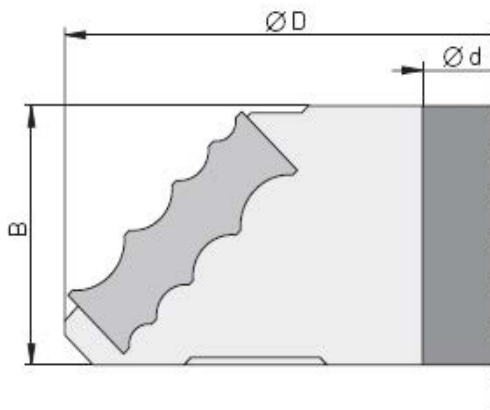

Hm afrond profielmessen

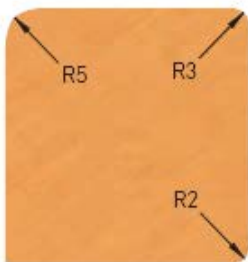

Art.-Nr./item no./num. art. 09.1925
Radius/radius/rayon 2, 3, 5

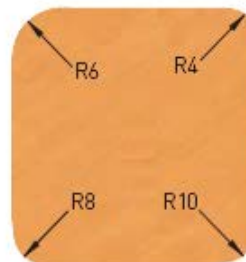
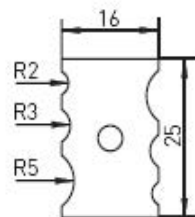

Art.-Nr./item no./num. art. 09.1950
Radius/radius/rayon 4, 6, 8, 10

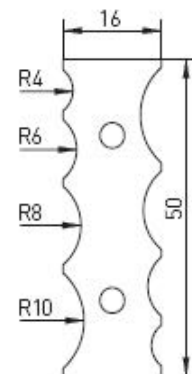

Multiprofielfrees

Hm keernes multiprofielfrees

Artikel-Nummer item no./num. art.	∅ D (mm)	B (mm)	d (mm)		z	n min. - max.	
14.120.040.030.A	120	40	30 - 40		2	6400 - 10000	
14.160.050.030.A	160	50	30 - 50		2	4800 - 8300	

MAN 

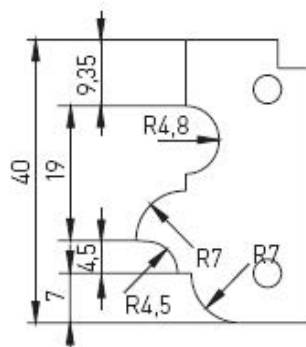
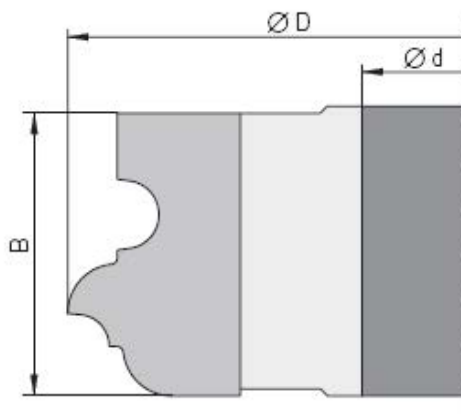

Art.-Nr./item no./num. art. 09.1401

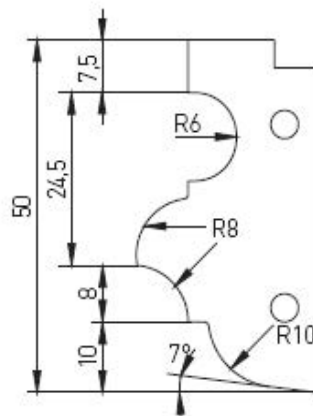

Art.-Nr./item no./num. art. 09.1402

Multiprofielfrees

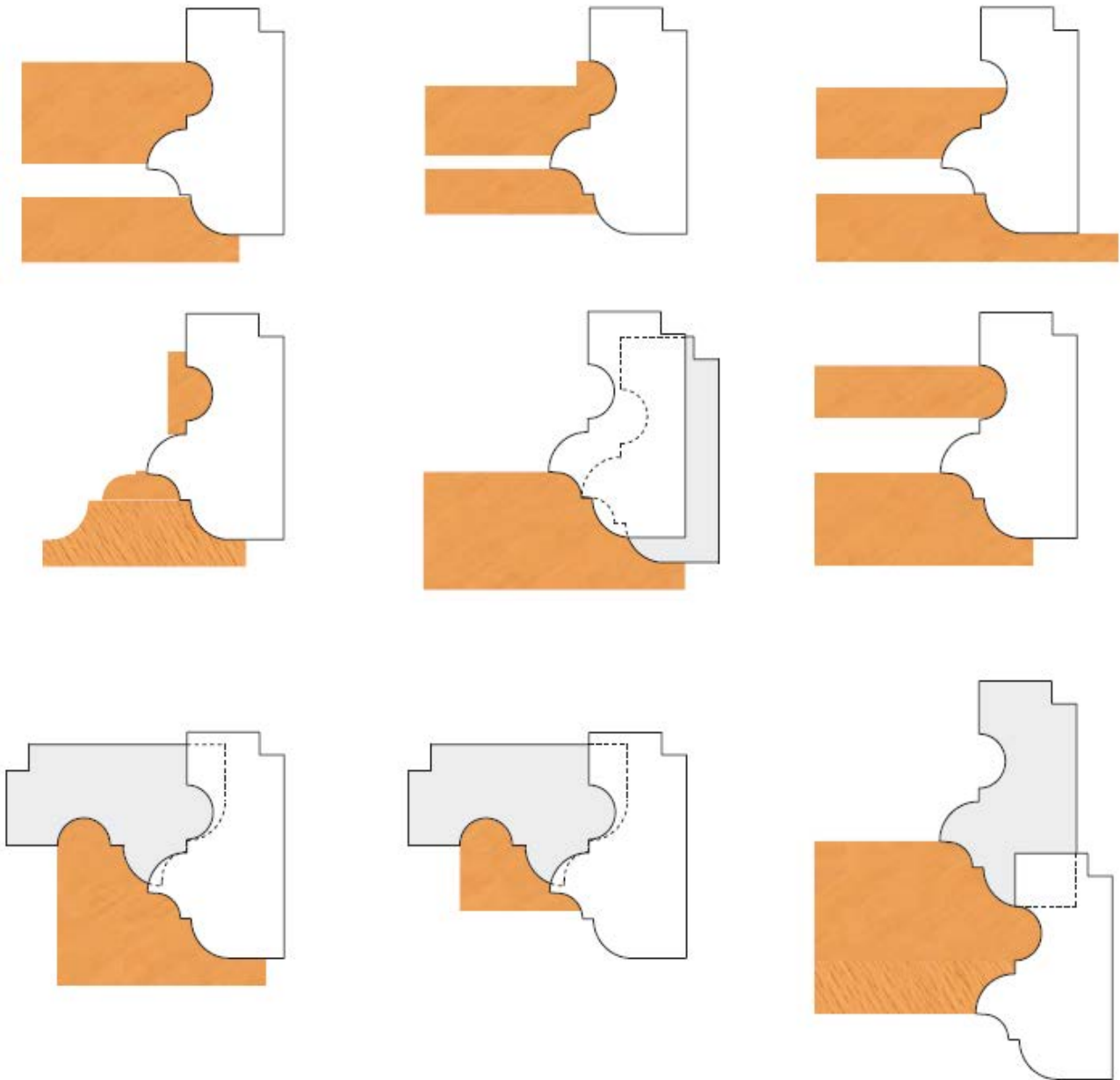

Hm profielmessen

Artikel-Nummer item no./num. art.	Beschreibung/description/description	Abmessung dimensions/dimensions	
09.1401	HW-Profielmesser / TC profile knife / plaquette profilée HW	40 x 25 x 2 mm	
09.1402	HW-Profielmesser / TC profile knife / plaquette profilée HW	50 x 27 x 2 mm	

Trapleuningfrees

Hin keermes trapleuningfrees

Artikel-Nummer item no./num. art.	∅ D (mm)	B (mm)	d (mm)		z	n min. - max.	
14.140.070.030.A	140	70	30 - 50		2	5500 - 9500	

MAN 

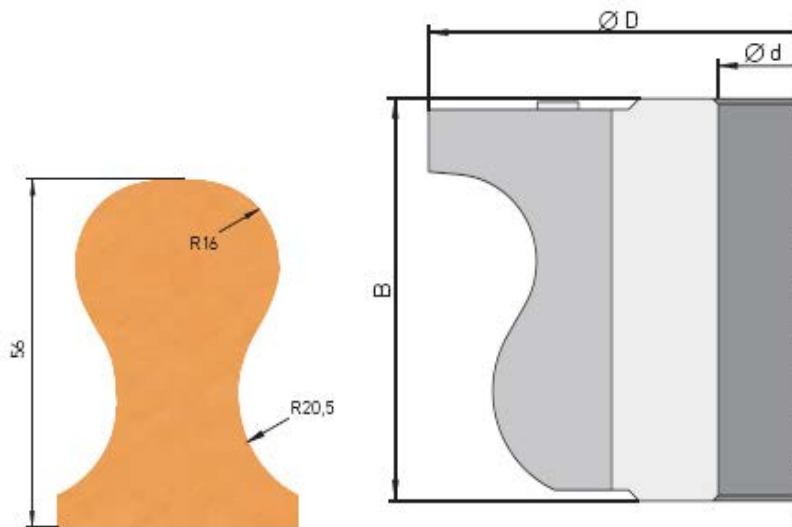

Schaafmessen

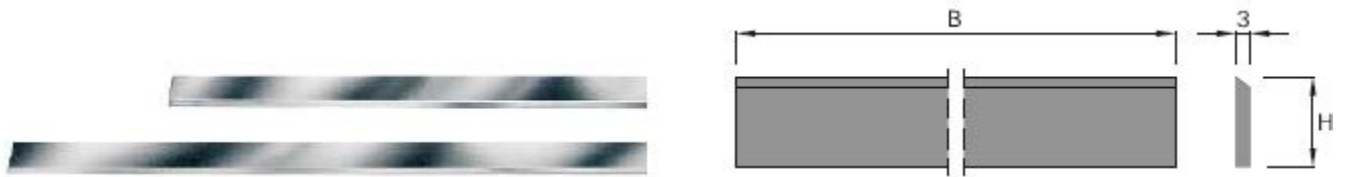

B	H	COD. HS	COD. HW
60	30	03670630HS	03670630HW
80	30	03670830HS	03670830HW
100	30	03671030HS	03671030HW
120	25	03671225HS	03671225HW
120	30	03671230HS	03671230HW
130	30	03671330HS	03671330HW
140	30	03671430HS	03671430HW
150	30	03671530HS	03671530HW
160	30	03671630HS	03671630HW
170	30	03671730HS	03671730HW
180	30	03671830HS	03671830HW
190	25	03671925HS	03671925HW
190	30	03671930HS	03671930HW
200	30	03672030HS	03672030HW
210	30	03672130HS	03672130HW

B	H	COD. HS	COD. HW
220	20	03672220HS	03672220HW
220	30	03672230HS	03672230HW
230	30	03672330HS	03672330HW
250	30	03672530HS	03672530HW
260	20	03672620HS	03672620HW
260	30	03672630HS	03672630HW
300	20	03673020HS	03673020HW
300	25	03673025HS	03673025HW
300	30	03673030HS	03673030HW
300	35	03673035HS	03673035HW
310	25	03673125HS	03673125HW
310	30	03673130HS	03673130HW
350	20	03673520HS	03673520HW
350	25	03673525HS	03673525HW
350	30	03673530HS	03673530HW
350	35	03673535HS	03673535HW
400	20	03674020HS	03674020HW
400	30	03674030HS	03674030HW
400	35	03674035HS	03674035HW

B	H	COD. HS	COD. HW
410	30	03674130HS	03674130HW
410	35	03674135HS	03674135HW
500	30	03675030HS	03675030HW
500	35	03675035HS	03675035HW
510	30	03675130HS	03675130HW
510	35	03675135HS	03675135HW
520	30	03675230HS	03675230HW
520	35	03675235HS	03675235HW
530	30	03675330HS	03675330HW
530	35	03675335HS	03675335HW
600	30	03676030HS	03676030HW
600	35	03676035HS	03676035HW
610	30	03676130HS	03676130HW
610	35	03676135HS	03676135HW
630	30	03676330HS	03676330HW
630	35	03676335HS	03676335HW
700	30	03677030HS	03677030HW
700	35	03677035HS	03677035HW

Hss langgatboor met spaanbrekers

D	LT	S	Z	COD. RH	COD. LH
6	105	13x50	2	05080613R0	05080613L0
6	105	16x50	2	05080616R0	05080616L0
7	110	13x50	2	05080713R0	05080713L0
7	110	16x50	2	05080716R0	05080716L0
8	115	13x50	2	05080813R0	05080813L0
8	115	16x50	2	05080816R0	05080816L0
9	120	13x50	2	05080913R0	05080913L0
9	120	16x50	2	05080916R0	05080916L0
10	125	13x50	2	05081013R0	05081013L0
10	125	16x50	2	05081016R0	05081016L0
11	130	13x50	2	05081113R0	05081113L0
11	130	16x50	2	05081116R0	05081116L0
12	135	13x50	2	05081213R0	05081213L0
12	135	16x50	2	05081216R0	05081216L0
13	140	13x50	2	05081313R0	05081313L0
13	140	16x50	2	05081316R0	05081316L0
14	145	13x50	2	05081413R0	05081413L0
14	145	16x50	2	05081416R0	05081416L0
15	150	13x50	2	05081513R0	05081513L0
15	150	16x50	2	05081516R0	05081516L0
16	155	13x50	2	05081613R0	05081613L0
16	155	16x50	2	05081616R0	05081616L0
17	160	13x50	2	05081713R0	05081713L0
17	160	16x50	2	05081716R0	05081716L0
18	165	13x50	2	05081813R0	05081813L0
18	165	16x50	2	05081816R0	05081816L0
19	170	13x50	2	05081913R0	05081913L0
19	170	16x50	2	05081916R0	05081916L0
20	175	13x50	2	05082013R0	05082013L0
20	175	16x50	2	05082016R0	05082016L0

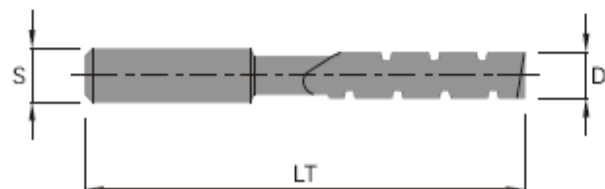
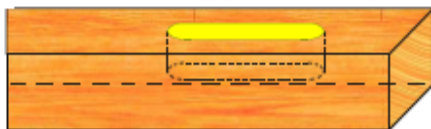

Set van 6 st. langgatboren

S	Z	COD. RH	COD. LH
13x50	2	05090013R0	05090013L0
16x50	2	05090016R0	05090016L0

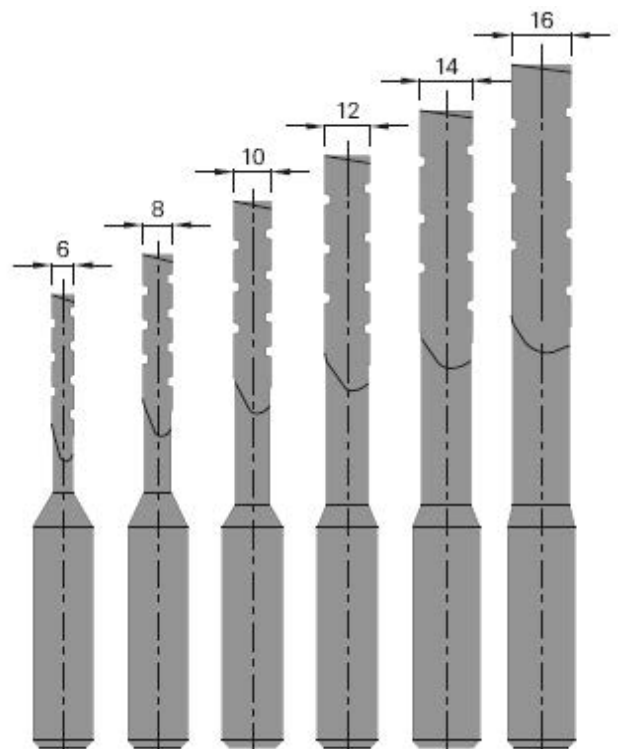
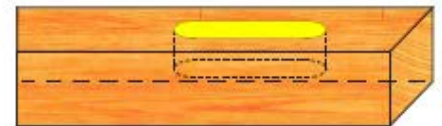

Tussenringen

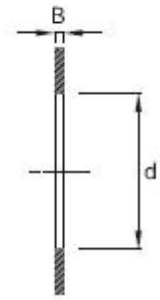
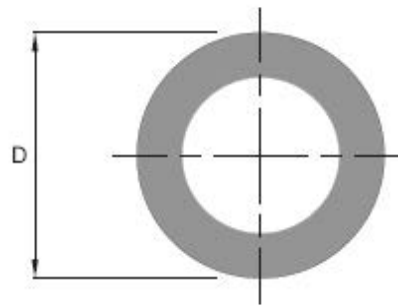

D	B	d	COD.
50	0.1	30	0371A00130
50	0.5	30	0371A00530
50	1	30	0371A01030
50	2	30	0371A02030
50	3	30	0371A03030
50	4	30	0371A04030
50	5	30	0371A05030
50	6	30	0371A06030
50	8	30	0371A08030
50	10	30	0371A10030
50	12	30	0371A12030
50	14	30	0371A14030
50	16	30	0371A16030
50	18	30	0371A18030
50	20	30	0371A20030

D	B	d	COD.
60	0.1	40	0371A00140
60	0.5	40	0371A00540
60	1	40	0371A01040
60	2	40	0371A02040
60	3	40	0371A03040
60	4	40	0371A04040
60	5	40	0371A05040
60	10	40	0371A10040
60	12	40	0371A12040
60	14	40	0371A14040
60	16	40	0371A16040
60	18	40	0371A18040
60	20	40	0371A20040

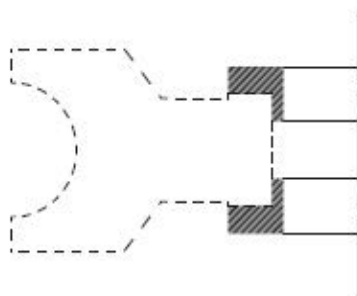
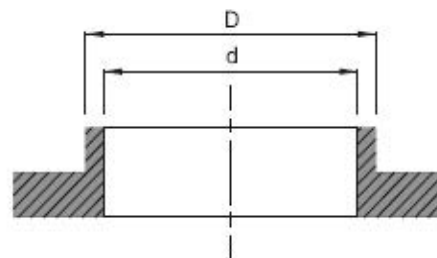

D	d	COD. (COPPIA/PAIR)
35	30	0373353000
40	30	0373403000
40	35	0373403500
50	30	0373503000
50	35	0373503500
50	40	0373504000
SPECIALE		0373SPECIA

Kopieerringen / lagers



Aanloopring



lager

aanloopring

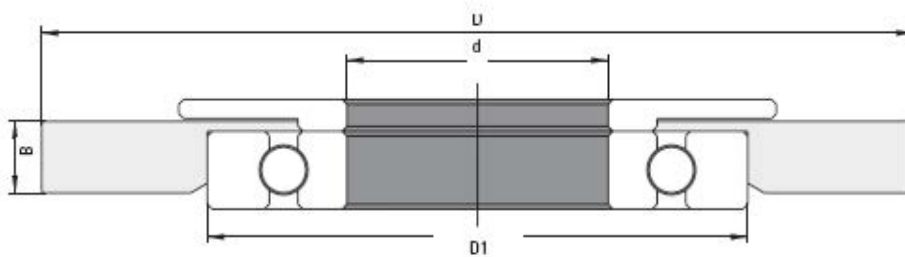

Aanloopringen

Artikel-Nummer item no./num. art.	omschrijving	∅ D (mm)	D1 (mm)	B (mm)	d (mm)	
09.075.016.062.A	aanloopring	75	62	16		
09.080.016.062.A	aanloopring	80	62	16		
09.085.016.062.A	aanloopring	85	62	16		
09.090.016.062.A	aanloopring	90	62	16		
09.095.016.062.A	aanloopring	95	62	16		
09.100.016.062.A	aanloopring	100	62	16		
09.105.016.062.A	aanloopring	105	62	16		
09.110.016.062.A	aanloopring	110	62	16		
09.115.016.062.A	aanloopring	115	62	16		
09.120.016.062.A	aanloopring	120	62	16		
09.125.016.062.A	aanloopring	125	62	16		
09.130.016.062.A	aanloopring	130	62	16		
09.135.016.062.A	aanloopring	135	62	16		
09.140.016.062.A	aanloopring	140	62	16		
09.145.016.062.A	aanloopring	145	62	16		
09.150.016.062.A	aanloopring	150	62	16		
09.6206-2RSR	lager		62		30	
09.065.054.030.S	afdekschijf				30	

Hm zaagbladen



Hm schulpzagen

250	3,2	2,2	30	22	FT01	LU1C 0100 ●
300	3,2	2,2	30	26	FT01	LU1C 0400 ●
315	3,2	2,2	30	28	FT01	LU1C 0800 ●
350	3,5	2,5	30	30	FT02	LU1C 1000 ●
400	4,0	2,8	30	34	FT02	LU1C 1300 ●



Hm universeel zaagbladen

D mm	B mm	b mm	d mm	Z	FT - NL	CODICE CODE
150	3,2	2,2	30	24	2/7/42	LU2A 0100 ●
180	3,2	2,2	30	30	2/7/42	LU2A 0500 ●
200	3,2	2,2	30	34	2/7/42	LU2A 0800 ●
210	3,2	2,2	30	34	2/7/42	LU2A 1100 ●
216	3,2	2,2	30	34		LU2A 1200 ●
220	3,2	2,2	30	34	2/7/42	LU2A 1300 ●
230	3,2	2,2	30	34	2/7/42	LU2A 1500 ●
250	3,2	2,2	30	40	FT01	LU2A 1700 ●
300	3,2	2,2	30	48	FT01	LU2A 2100 ●
315	3,2	2,2	30	48	FT01	LU2A 2400 ●
350	3,5	2,5	30	54	FT02	LU2A 2800 ●
400	4,0	2,8	30	60	FT02	LU2A 3300 ●
450	4,4	3,0	30	66	FT02	LU2A 3600 ●



Hm afkort / platenzaag

D mm	B mm	b mm	d mm	Z	FT - NL	CODICE CODE
150	3,2	2,2	30	36	2/7/42	LU2B 0100 ●
180	3,2	2,2	30	42	2/7/42	LU2B 0200 ●
200	3,2	2,2	30	48	2/7/42	LU2B 0300 ●
216	3,2	2,2	30	48		LU2B 0400 ●
250	3,2	2,2	30	48	FT01	LU2B 0500 ●
250	3,2	2,2	35	60		LU2B 0800 ●
300	3,2	2,2	30	60	FT01	LU2B 0900 ●
300	3,2	2,2	30	72	FT01	LU2B 1100 ●
315	3,2	2,2	30	72	FT01	LU2B 1300 ●
350	3,5	2,5	30	72	FT02	LU2B 1400 ●
350	3,5	2,5	30	84	FT02	LU2B 1600 ●
400	4,0	2,8	30	96	2/10/60	LU2B 1900 ●
450	4,4	3,0	30	96	2/10/60	LU2B 2000 ●

Hm zaagbladen



Hm platenzaag (wisseltand)

D mm	B mm	b mm	d mm	Z	FT - NL	CODICE CODE
150	3,2	2,2	30	48	2/7/42	LU2C 0100 ●
160	3,2	2,2	20	48	2/6/32	LU2C 0200 ●
180	3,2	2,2	30	56	2/7/42	LU2C 0400 ●
190	3,2	2,2	30	56	2/7/42	LU2C 0500 ●
200	3,2	2,2	30	64	2/7/42	LU2C 0600 ●
210	3,2	2,2	30	64	2/7/42	LU2C 0700 ●
216	3,2	2,2	30	64	2/7/42	LU2C 0800 ◡
220	3,2	2,2	30	64	2/7/42	LU2C 0900 ●
230	3,2	2,2	30	64	2/7/42	LU2C 1000 ●
250	3,2	2,2	30	80	FT01	LU2C 1200 ●
300	3,2	2,2	30	96	FT01	LU2C 1500 ●
330	3,2	2,2	20	96	2/6/32	LU2C 1800 ●
350	3,5	2,5	30	108	FT02	LU2C 2000 ●
400	3,8	2,8	30	120	2/10/60	LU2C 2100 ●



Hm platenzaag (daktand)

D mm	B mm	b mm	d mm	Z	α	FT - NL	CODICE CODE
200	3,2	2,2	30	64	5°	2/7/42	LU3D 0100 ●
220	3,2	2,2	30	64	5°	2/7/42	LU3D 0200 ●
250	3,2	2,2	30	80	5°	FT01	LU3D 0400 ●
300	3,2	2,2	30	96	5°	FT01	LU3D 0600 ●
350	3,5	2,5	30	108	5°	FT02	LU3D 0900 ●



Hm ritszaag

D mm	B mm	d mm	Z	MACCHINE MACHINES	CODICE CODE
80	2,8-3,6	20	10+10	Felder	LI16M HA3 ●
80	2,8-3,6	20	12+12	Felder	LI16M GA3 ●
100	2,8-3,6	20	12+12	Panahans - Schelling	LI16M BA3 ●
100	2,8-3,6	22	12+12	Altendorf - Striebig	LI16M BB3 ●
105	2,8-3,6	20	10+10	GMC	LI16M CA3 ●
120	2,8-3,6	20	12+12	Holz Her - SCM	LI16M AA3 ●
120	2,8-3,6	22	12+12	Altendorf - Martin	LI16M AB3 ●
120	2,8-3,6	50	12+12	Altendorf - SCM - Griggio	LI16M PF3 ●
120	4,0-5,0	50	12+12	Altendorf - SCM - Griggio	LI16M IF3 ◡
125	2,8-3,6	20	12+12	Paoloni	LI16M FA3 ●
125	2,8-3,6	20	14+14	Paoloni	LI16M EA3 ●
125	2,8-3,6	22	14+14		LI16M EB3 ●
125	4,0-4,7	20	20+20	Paoloni	LI16M DA3 ●
125	4,0-5,0	45	12+12	Giben - Mayer	LI16M KE3 ◡
125	4,0-5,0	50	12+12	Paoloni - Panahans	LI16M KF3 ◡

Nederlandse standaard profielen

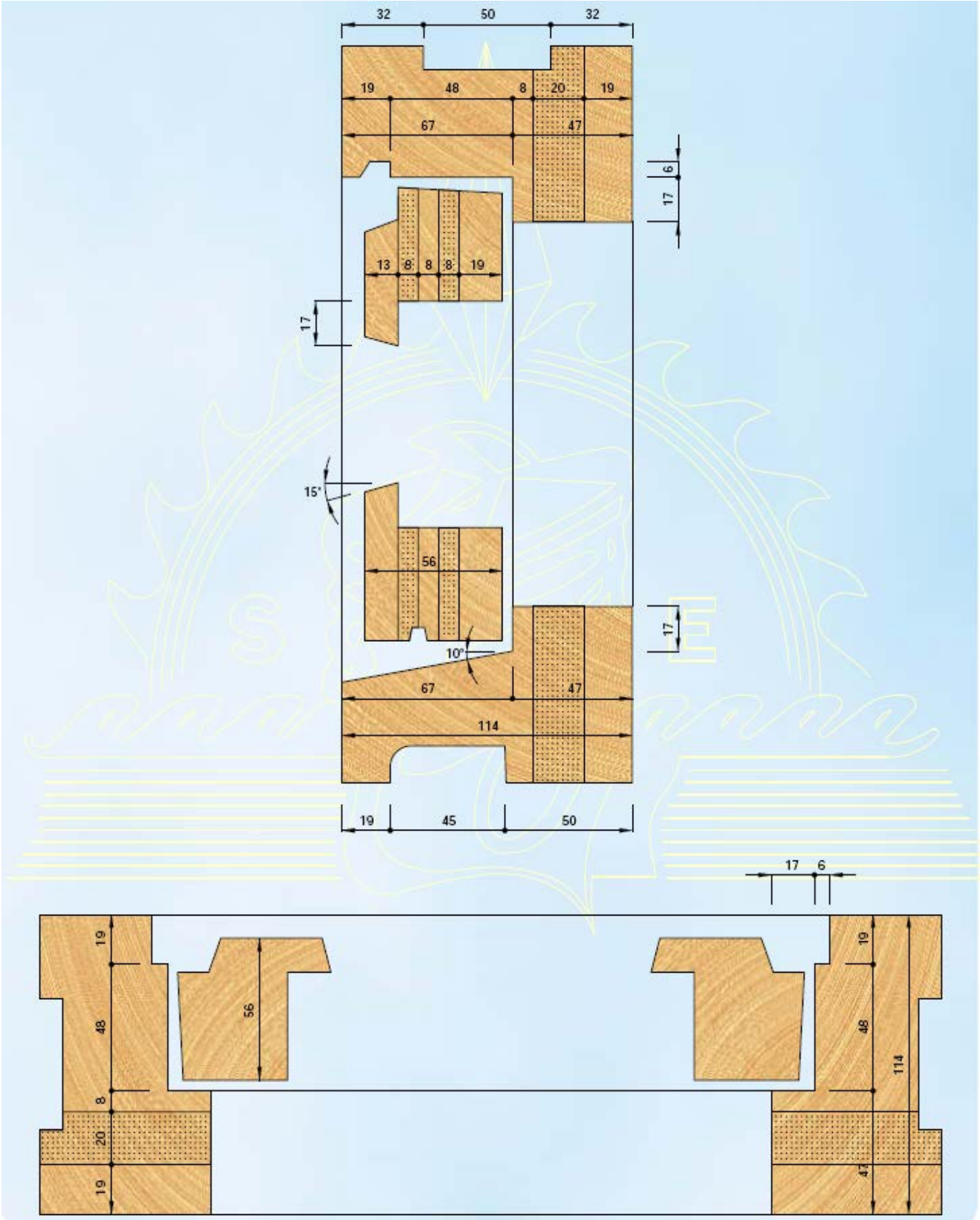

Nederlandse standaard profielen

<p>POS.01 stijl met scharnieropening</p>	<p>POS.02 bovendorpel</p>
<p>POS.03 onderdorpel</p>	<p>POS.08 centra stijl</p>
<p>POS.04 muuraansluiting</p>	<p>POS.09 centra onderdorpel</p>
<p>POS.05 waterslag dorpelopening</p>	<p>POS.10 sluisen onder bovendorpel</p>
<p>POS.06 ramen 56 mm.</p>	<p>POS.11 dubbele penramen</p>
<p>POS.12 sluisen ramen</p>	<p>POS.12 sluisen ramen</p>



Hm keermessen

HW

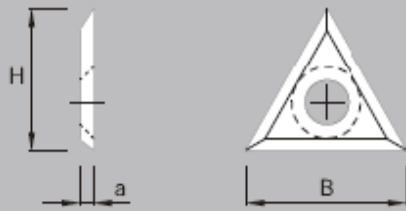

B	H	a	COD.
22	20	2	0480020000

HW

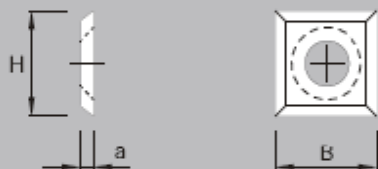

B	H	a	COD.
14	14	2	0480030014

HW



B	H	a	COD.
7.5	12	1.5	0480050007
9	12	1.5	0480050009
11	12	1.5	0480050011
12	12	1.5	0480050012
15	12	1.5	0480050015
16	12	1.5	0480050016
17	12	1.5	0480050017
20	12	1.5	0480050020
30	12	1.5	0480050030
40	12	1.5	0480050040
50	12	1.5	0480050050
60	12	1.5	0480050060
80	13	2.2	0480050080
100	13	2.2	0480050100

HW

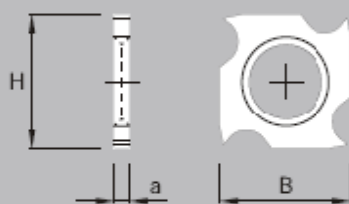

B	H	a	COD.
18	13	1.95	048020A000

HW

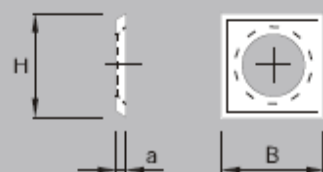

B	H	a	COD.
14	14	1.2	048020B000

Stelklokken

Hebor H-50 meetklok



Aigner distometer



